

Scambiatori Aria-olio Serie HPV

*Air-oil heat-exchangers
HPV Series*



ENNEGI

Gli scambiatori di calore aria-olio EMMEGI, sono impiegati per il raffreddamento di circuiti oleodinamici usando, come fluido raffreddante, l'aria ambiente convogliata sulla radiante da una ventola azionata da un motore elettrico o idraulico. La massa radiante, in lega d'alluminio ad alta resistenza, è ottenuta mediante un processo costruttivo di saldobrasatura sottovuoto. La particolare configurazione dei condotti aumenta la turbolenza del fluido e di conseguenza la capacità di scambio; inoltre la presenza di speciali turbolatori sull'alettatura del pacco radiante, migliora ulteriormente il coefficiente di trasmissione totale. Il risultato è un prodotto tecnologicamente avanzato di dimensioni contenute, leggero e robusto. Gli scambiatori aria-olio serie HPV- nascono dalle esigenze applicative ad ampio raggio espresse dal mercato. Punto di forza di questi prodotti è rappresentato dal by-pass integrato che ne amplifica la semplicità d'uso, eliminando la necessità di dovere aggiungere da parte del cliente una valvola autonoma, assicurando così elevata funzionalità.

Fluidi compatibili

- . OIL MINERALI, HL, HLP.
- . EMULSIONI ACQUA-OLIO
- . ACQUA-GLICOLE
- . Per altri fluidi consultare EMMEGI.

Specifiche tecniche Masse Radianti

- . Materiale: alluminio "long life".
- . Pressione d'esercizio: 20 bar.
- . Pressione di collaudo: 35 bar.
- . Temperatura max d'esercizio: 120°C
- . Per particolari atmosfere aggressive consultare l'EMMEGI.

Installazione

Lo scambiatore può essere montato in posizione orizzontale o verticale, rispettando la distanza minima dalla parete (vedi fig. 1), in modo da assicurare un naturale afflusso e deflusso dell'aria di raffreddamento.

Lo scambiatore è installato di norma, sulle tubazioni di ritorno dell'olio del serbatoio; deve inoltre essere protetto da urti e vibrazioni meccaniche mediante supporti e collegato all'impianto con tubazioni flessibili. È necessario evitare che sia sottoposto a brusche variazioni di portata, colpi d'ariete e pulsazioni continue che danneggiano in modo irreversibile la radiante.

Per preservare lo scambiatore dalla sovrappressione che si genera all'avviamento dell'impianto per elevata viscosità dell'olio, si suggerisce l'inserimento di una valvola di by-pass (vedi fig.2).

EMMEGI air-oil heat exchangers are used for cooling oil hydraulic systems using as the coolant ambient air that passes over the radiant by means of a fan operated by an electric or hydraulic motor. The cooler element, in high resistance aluminium alloy, is obtained by means of a braze-welding process carried out under vacuum.

The particular configuration of the cooling pipes increase the turbulence of the fluid consequently of the exchange capacity; moreover, the presence of special jets on the cooler finning further improves the total transmission coefficient.

The result is a very small, light and robust technologically advanced product.

The air-oil heat-exchangers HPV Series were born to answer the large application needs of the market.

The main characteristic of this new products is the integrated by-pass valve that will simplify their employ and will avoid the customers to add an external and independent valve.

This will guarantee a very high efficiency.

Compatible fluids

- . MINERAL OILS; HL; HLP.
- . WATER-OIL EMULSION.
- . WATER-GLYCOL.
- . Consults EMMEGI for other fluids.

Technical specification of Cooler Element

- . Material: "long life" aluminium.
- . Operating pressure: 20 bar
- . Test pressure: 35 bar.
- . Max operating temperature: 120°C.
- . For specially "aggressive" atmospheres contact EMMEGI.

Installation

The exchangers can be fitted in a horizontal position, respecting the minimum distance from the wall (see fig.1) so as to ensure a natural flow of cooling air.

The exchangers is usually installed on oil tank return piping; it must also be protected from impacts and mechanical vibrations by supports and must be connected to the plant with flexible pipes.

Avoid subjecting the exchanger to sudden changes in flow, hammering and pulsations that can cause irreversible damage to the element.

We recommend installing a by-pass valve (see fig.2) to protect the exchanger from over-pressure generated when the plants is started up due to high oil viscosity.

Manutenzione

È buona norma prestare particolare attenzione alla pulizia della massa radiante per garantire un naturale ricambio d'aria, ed evitare una diminuzione dell'efficienza termica.

Pulizia lato olio

Per eseguire la pulizia lato olio, lo scambiatore dovrà essere smontato. Lo sporco può essere rimosso flussando in controcorrente un prodotto sgrassante, compatibile con alluminio. Effettuate un lavaggio con olio idraulico prima di ricollegare il prodotto all'impianto.

Pulizia lato aria

La pulizia lato aria può essere effettuata con aria compressa o acqua, con direzione del getto parallelo alle alette per non danneggiare. Lo sporco oleoso o grasso può essere rimosso con getto di vapore o acqua calda. Durante questa operazione, il motore elettrico non deve essere collegato alla tensione, e dovrà essere adeguatamente protetto.

Esempio di scelta dello scambiatore

Per effettuare la scelta dello scambiatore si procede come segue:

Potenza da dissipare : 19,5 [KW]
Portata olio ISO VG 32 : 90 [lpm]
Temperatura ingresso olio : 60 [°C]
Temperatura ambiente : 30 [°C]
Ventola azionata da motore elettrico 230/400V-50Hz.

Si calcola la potenza specificata di scambio espressa in KW/°C, conoscendo la potenza da dissipare e il ΔT (differenza tra la temperatura olio ingresso e la temperatura ambiente).

$$P = \frac{19.5 \text{ KW}}{60^\circ - 30^\circ} = 0.65 \text{ KW/}^\circ\text{C}$$

Nota la portata olio (90 lpm) e la potenza specifica di scambio (0.65 KW/°C) si procede alla ricerca del prodotto avvalendosi dei grafici riportati a catalogo, relativi ai singoli modelli.

Maintenance

You should be particularly carefully in cleaning the cooler element to guarantee a natural exchange of air, in order to prevent a reduction in thermal efficiency

Cleaning oil side

The exchanger should be dismantled to clean on the oil side. The dirt can be removed by flushing, in counter-current, de-greasing substance, compatible with aluminium. Wash with hydraulic oil before re-connecting the product to the plant.

Cleaning air side

Cleaning on the air side can be done using compressed air or water, directing the jet parallel to the fins so as not to damage them. Oily dirt or grease can be removed with a jet of steam or hot water. During this operation, the electric motor must be disconnected from the voltage supply, and must be adequately protected.

Example of how to choose a heat exchanger

Proceed with sizing the exchanger, with a knowledge of the data as the example below shows:

Power to dissipate : 19,5 [KW]
ISO VG 32 oil flow : 90 [lpm]
Oil input temperature : 60 [°C]
Ambient temperature : 30 [°C]
Fan operating with an electric motor 230/400V-50Hz.

You can then calculate the specific heat exchange power KW/°C if you know the power to dissipate and the ΔT (the difference between the oil input temperature and the ambient temperature).

$$P = \frac{19.5 \text{ KW}}{60^\circ - 30^\circ} = 0.65 \text{ KW/}^\circ\text{C}$$

Note the oil flow (90 lpm) and specific exchange power (0.65 KW/°C), product research is made by referring to the graph in the catalogue which is relevant to each model.

Dati tecnici Technical Data



P/N	V	Hz	kW	A	rpm	ø Fan	dB(A)	(m³/h)	IP	lt	Kg
2V3003 ###	230-400 B14 AC	50	0,75	3,46-1,90	1394	450	82	4000	55		37
	280-480 B14 AC	60	0,90	3,41-1,99	1673						
2V3012 ###	12 DC	/	0,115	9,58	2530	280	74	1550	67	6,8	32
2V3024 ###	24 DC	/	0,125	5,20	2900	280	78	1700	67		32
2V3056 ###	Prepared for Gr.2 hydraulic motor					450			/		35

Per il 12-24V i dati sono riferiti al singolo ventilatore For 12-24V the data refers to each ventilator

☎ Contattare EMMEGI Contact EMMEGI

Diagramma rendimento Performance diagram

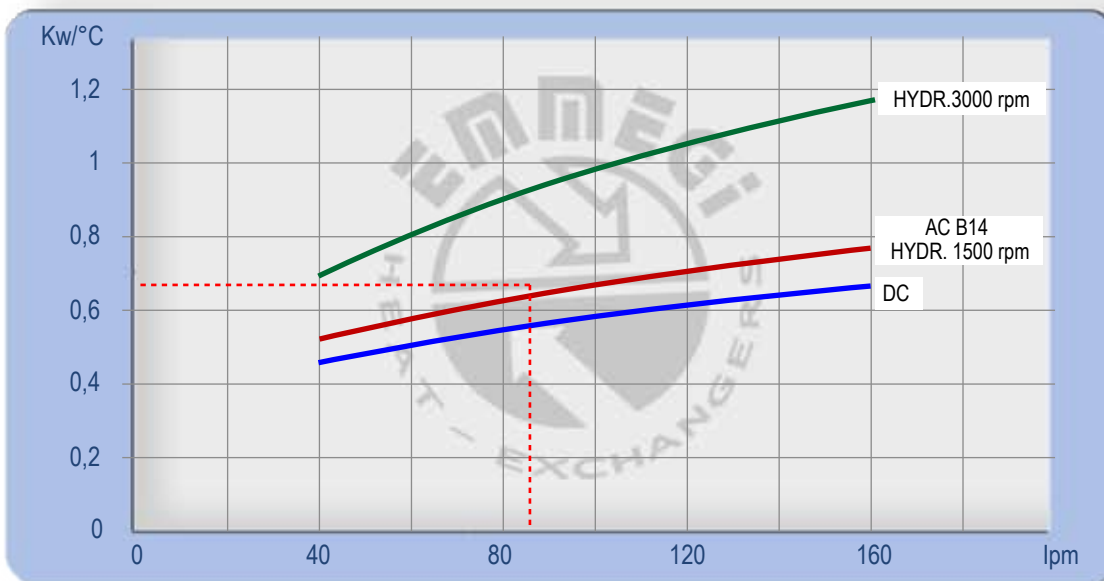

Lo scambiatore selezionato risulta il modello:
HPV 30 - 230/400 - 50Hz
cod. 2V3003###.

The exchanger selected is the following model:
HPV 30 - 230/400V - 50Hz
cod. 2V3003###.

Per la completa identificazione dello scambiatore consultare la pagina "DENOMINAZIONE CODICE PRODOTTO". Nel caso non siano conosciuti tutti i dati, per la scelta prendere contatto **EMMEGI**.

For a complete description of the exchanger consult the "PRODUCT ORDERING CODE" page. If you do not know all the data required for selecting the model, contact **EMMEGI**.

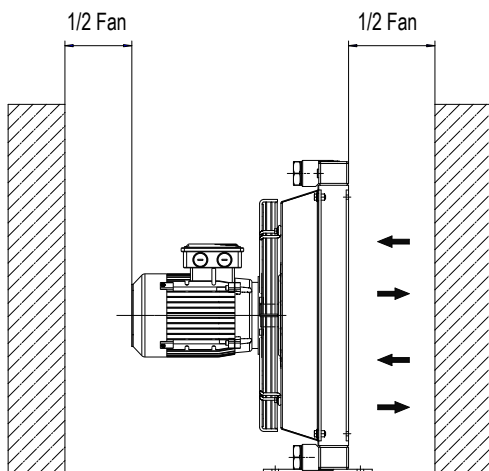

Fig.1

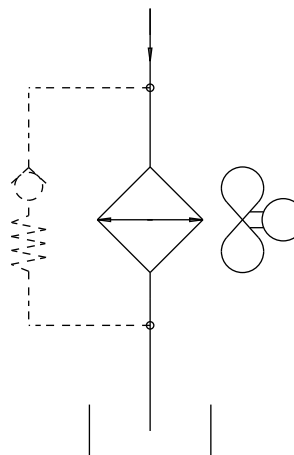
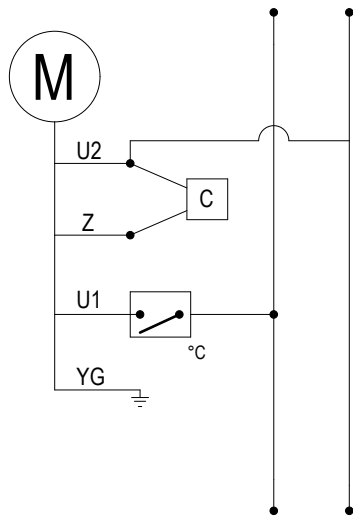

Fig.2

Collegamenti elettrici

Electric Wiring



230V AC 1 PHASE

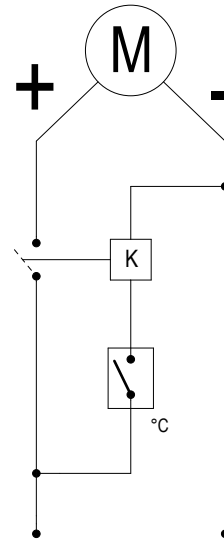

12-24V DC

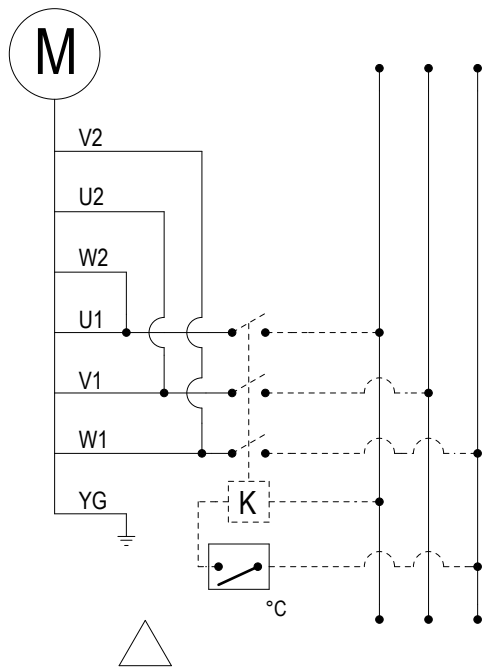

230V AC 3 PHASE

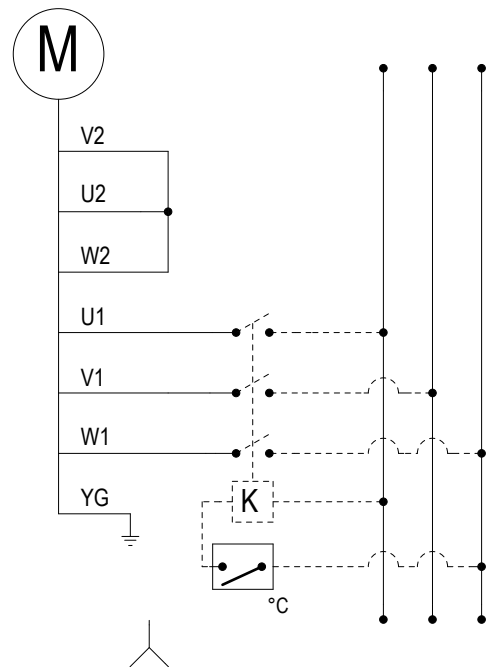

400V AC 3 PHASE

°C = Termostato NA./Thermostat No.
K = Relè/Relay

Modulo richiesta dati

Sheet for cooler selection



CLIENTE COMPANY	
RICHIEDENTE NAME	

ARIA-OLIO AIR-OIL

PORTATA OLIO OIL FLOW RATE	Imp	
POTENZA INSTALLATA TOTAL POWER	KW	
POTENZA DA DISSIPARE POWER TO BE DISSIPATED	KW	
TEMPERATURA INGRESSO OLIO OIL TEMPERATURE INLET	°C	
TEMPERATURA ARIA MAX MAX AMBIENT TEMPERATURE	°C	
VISCOSITÀ OLIO OIL VISCOSITY	cst	
PRESSIONE DI LAVORO WORKING PRESSURE	bar	

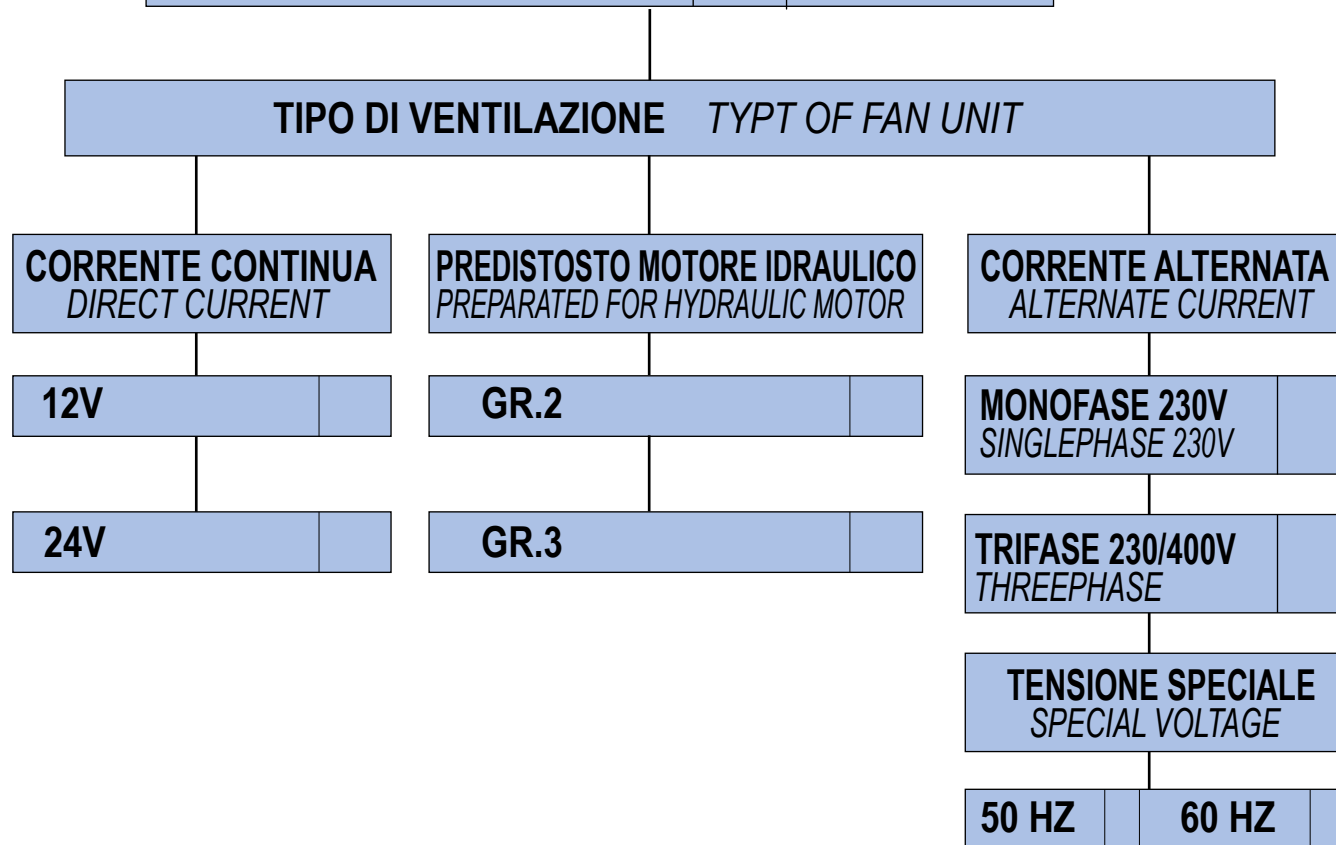

2

V24

03

2

01

TIPO DI SISTEMA COOLER SERIES

V24 (HPV 24)

TIPO DI MOTORIZZAZIONE FAN MOTOR TYPE

- 01 AC 230V 50 Hz
- 03 AC 230V-400V 50Hz
- 04 AC 230V-400V 50-60 Hz (B14)
- 12 DC 12V
- 24 DC 24V
- 56 Pred. per mot. idr. gr. 2 Prep. for hydr. mot. gr. 2

TERMOSTATI THERMOSTATS

- | | | | |
|---|---------------------------------|---------------------------------|--------------|
| 1 | Termostato fisso | Fixed thermostat | 40-28° |
| 2 | Termostato fisso | Fixed thermostat | 50-38° |
| 3 | Termostato fisso | Fixed thermostat | 60-48° |
| 4 | Termostato fisso | Fixed thermostat | 70-58° |
| 5 | Termostato fisso | Fixed thermostat | 80-68° |
| 6 | Termostato fisso | Fixed thermostat | 90-78° |
| 8 | Termostato regolabile | Adjustable thermostat | 0-90° (TC2) |
| 9 | Termostato regolabile collegato | Connected adjustable thermostat | 0-120° (TC2) |

TIPO DI VENTILAZIONE VENTILATING TYPE

- 01 Aspirante Suction air flow
- 02 Soffiante Blowing air flow

Dati tecnici valvola by-pass Technical data by-pass valve - (1.5 bar)



Detail

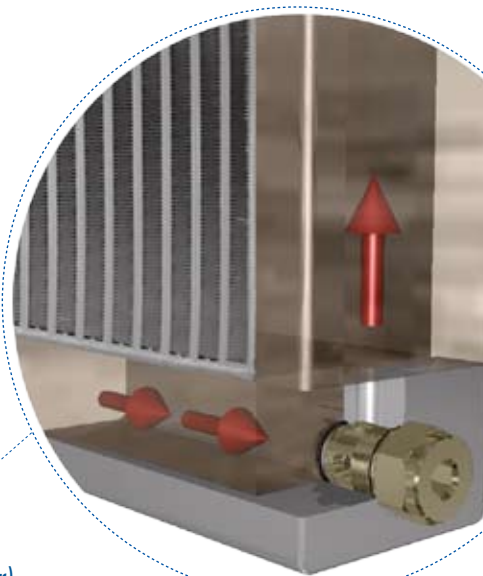

Valvola cartuccia tipo 2 / Cartridge valve type 2 - (1.5 bar)

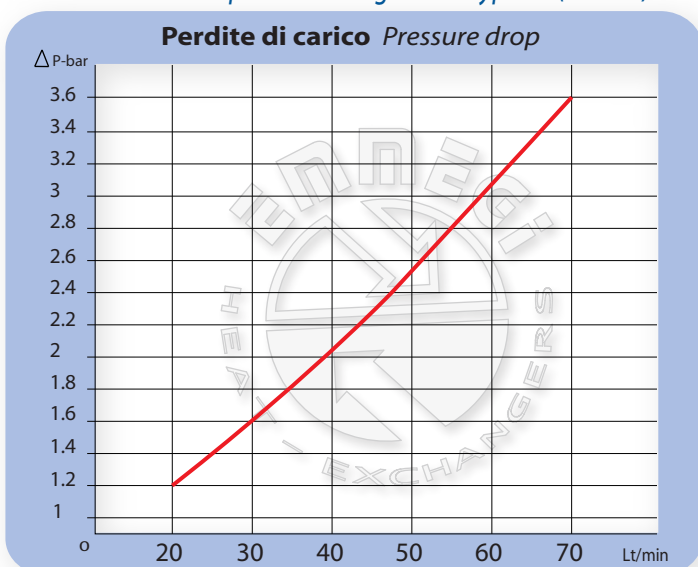

Gli scambiatori aria -olio serie HPV- nascono dalle esigenze applicative ad ampio raggio espresse dal mercato.

Punto di forza di questi prodotti é rappresentato dal by-pass integrato che ne amplifica la semplicità d' uso, eliminando la necessità di dovere aggiungere da parte del cliente una valvola autonoma, assicurando così elevata funzionalità.

The air-oil heat-exchangers HPV Series were born to answer the large application needs of the market. The main characteristic of this new products is the integrated by-pass valve that will simplify their employ and will avoid the customers to add an external and independent valve. This will guarantee a very high efficiency.

Valvola cartuccia tipo 3 / Cartridge valve type 3 - (1.5 bar)

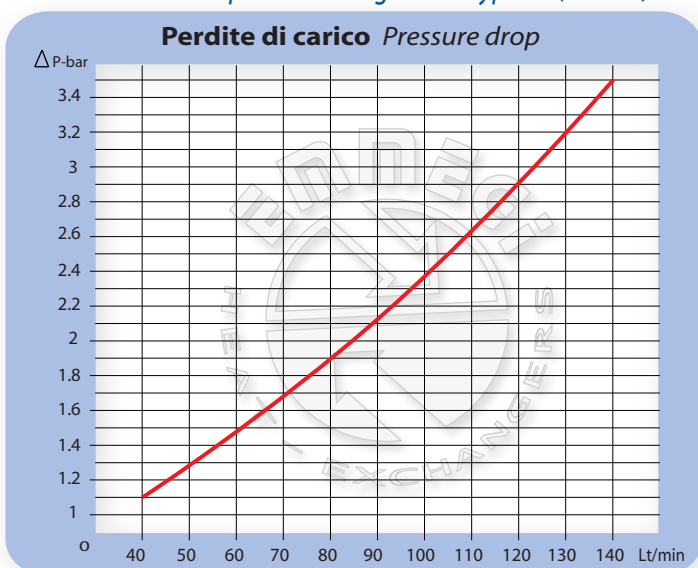

Schema idraulico Hydraulic circuit

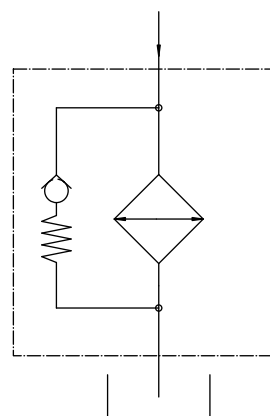

Dimensioni Dimensions

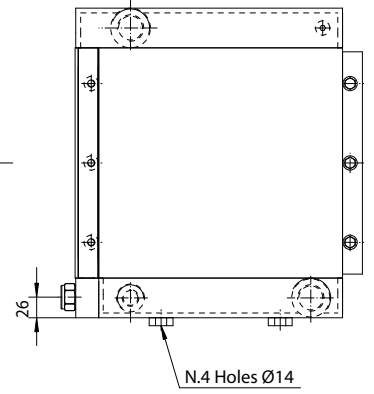
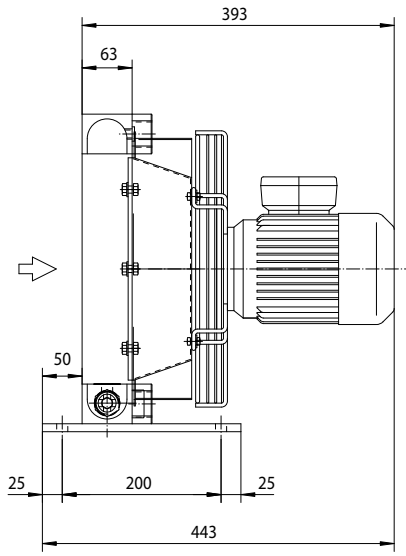
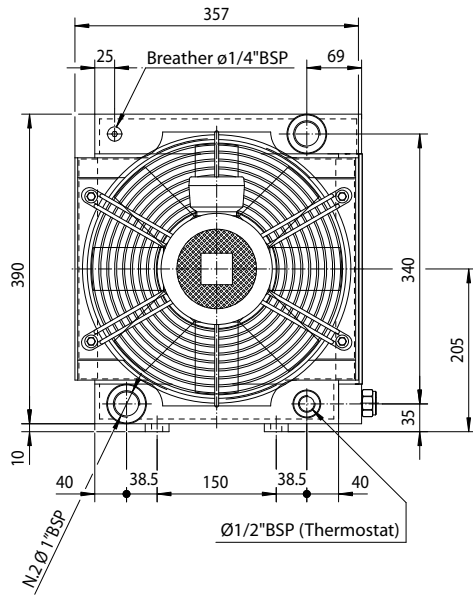

P/N 2V1203###

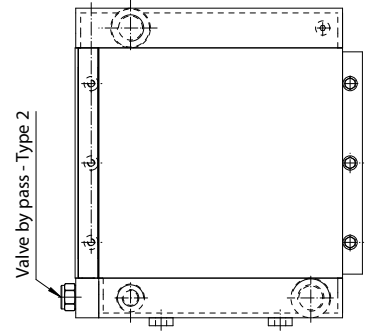
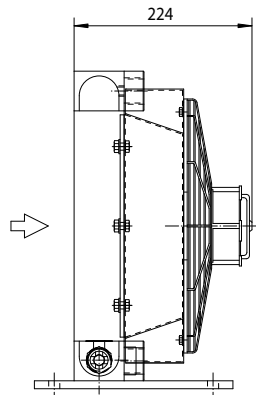
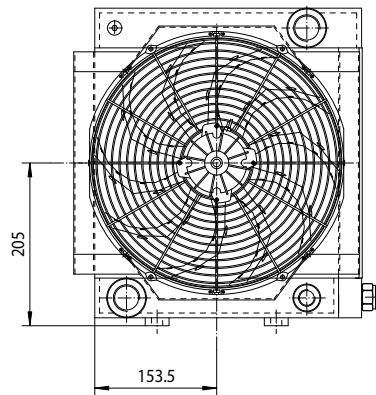

P/N 2V1212###
P/N 2V1224###

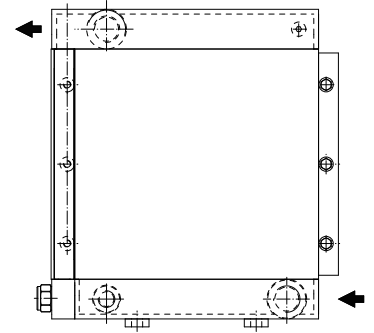
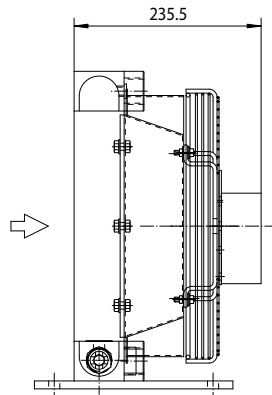
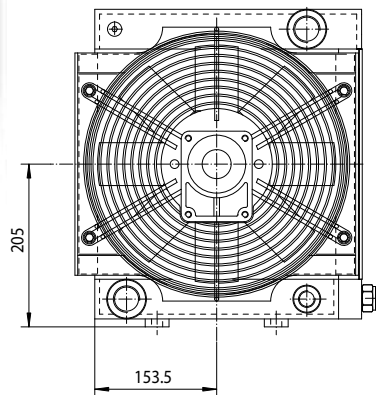

P/N 2V1256###

Le dimensioni di ingombro e le caratteristiche tecniche non sono impegnative
Over-all dimensions and technical characteristic are not binding

Dati tecnici Technical Data



HPV 12
A11

P/N	V	Hz	kW	A	rpm	ø Fan	dB(A)	(m³/h)	IP	lt	Kg
2V1203 ###	230-400 B14 AC	50	0,250	1,2-0,69	1400	315	72	1670	55	1,9	17
	280-480 B14 AC	60	0,3	1,18-0,69	1680		☎				
2V1212 ###	12 DC	/	0,111	9,30	2600	305	77	1590	67		15
2V1224 ###	24 DC	/	0,148	6,15	3100	305	80	1700	67		15
2V1256 ###	Prepared for Gr.2 hydraulic motor				☎	315	☎	☎	/		16

☎ Contattare EMMEGI Contact EMMEGI

Diagramma rendimento Performance diagram

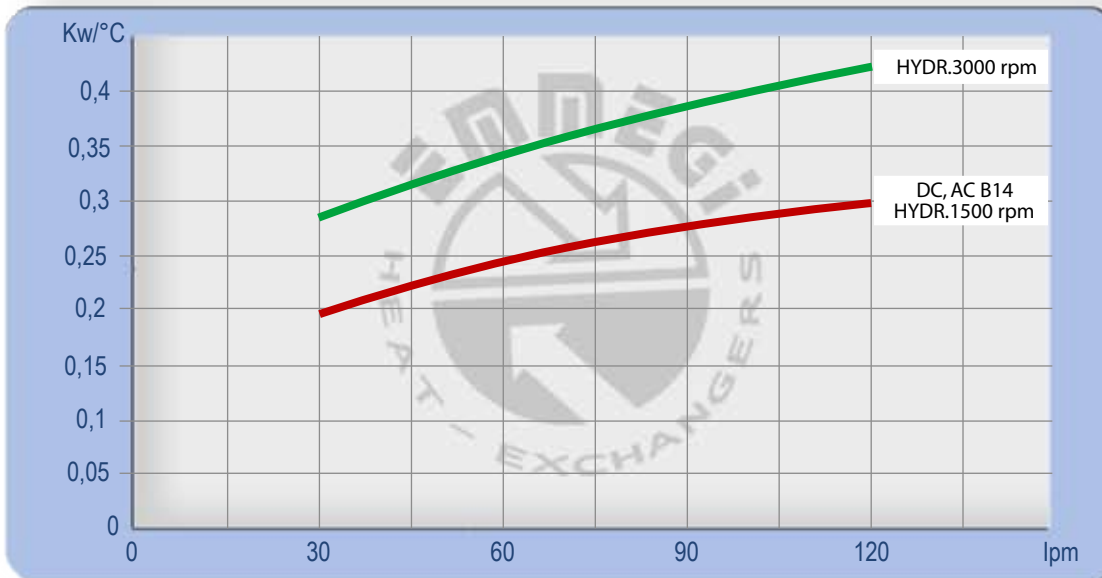

Perdite di carico Pressure drop (ISO VG 32)

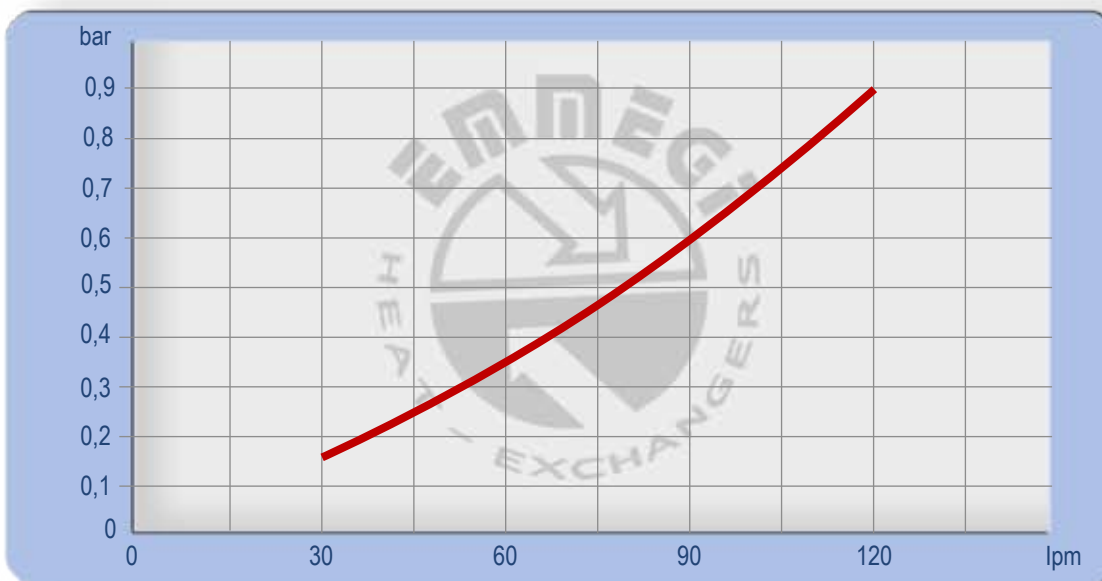

Fattore di correzione - F - (perdite di carico) Correction factor - F - (Pressure drop)

cst	10	15	20	30	40	50	60	80	100	200	300
F	0,5	0,65	0,77	1	1,2	1,4	1,6	1,9	2,1	3,3	4,3

Dimensioni Dimensions

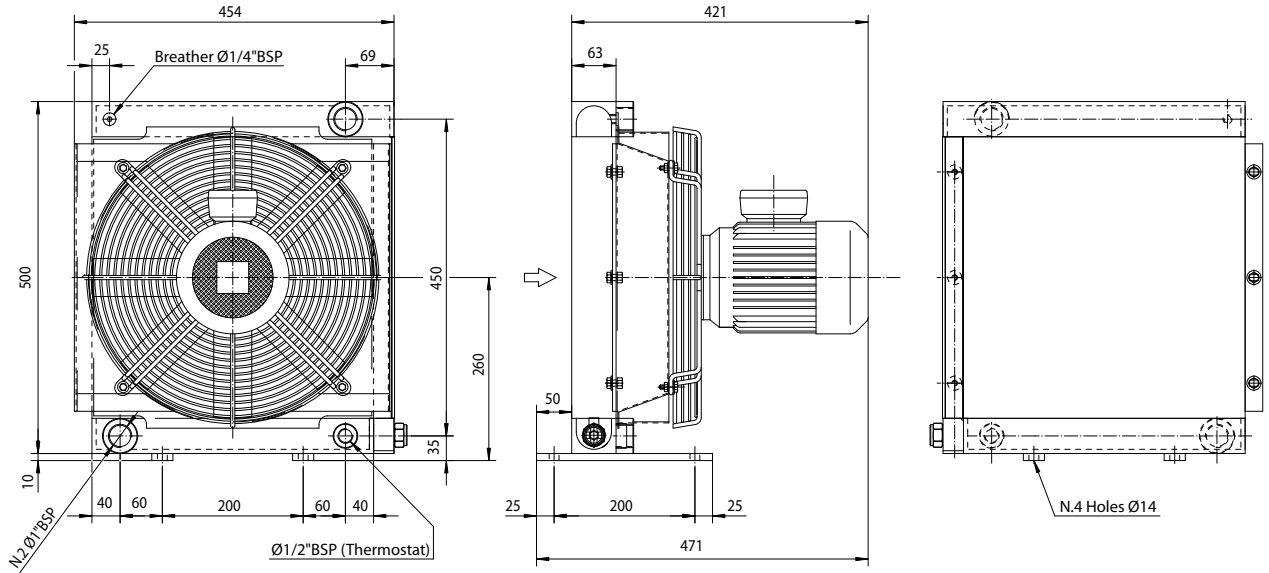

P/N 2V1803###

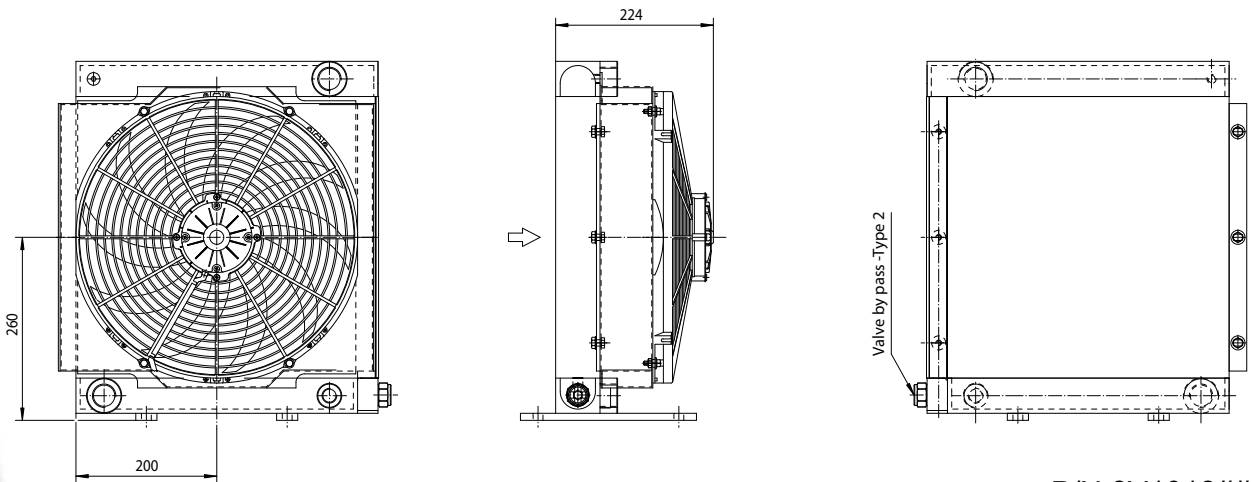

P/N 2V1812###
P/N 2V1824###

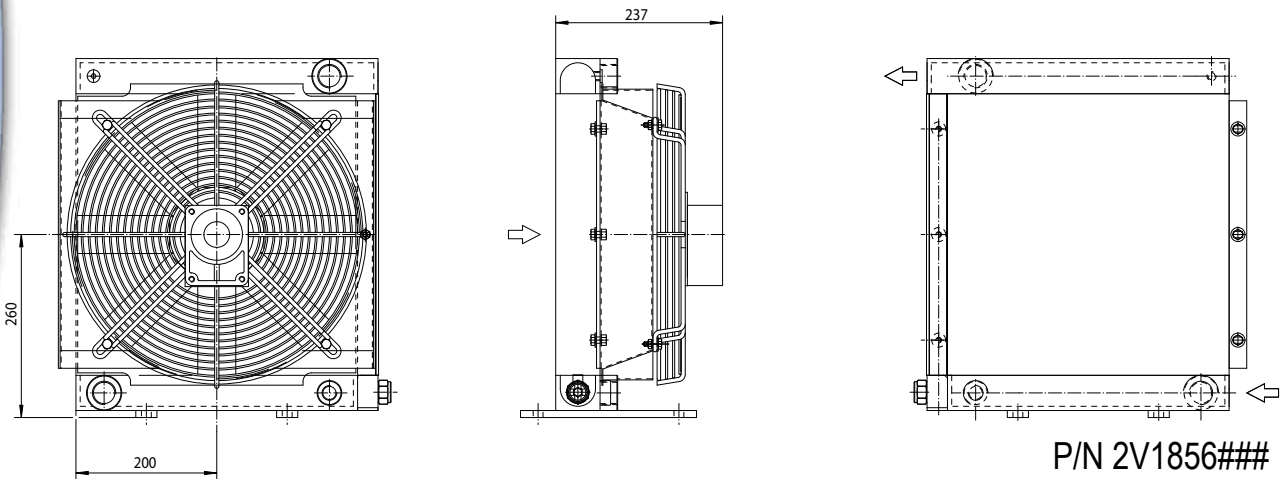

P/N 2V1856###

Le dimensioni di ingombro e le caratteristiche tecniche non sono impegnative
Over-all dimensions and technical characteristic are not binding

Dati tecnici Technical Data



HPV 18

P/N	V	Hz	kW	A	rpm	ø Fan	dB(A)	(m³/h)	IP	lt	Kg
2V1803 ###	230- 400 B14 AC	50	0,37	1,81-1,04	1366	400	77	3350	55	2,9	20
	280- 480 B14 AC	60	0,44	1,78-1,04	1639		☑	☑			
2V1812 ###	12 DC	/	0,187	15,6	2350	385	77	2950	67		18
2V1824 ###	24 DC	/	0,170	7,1	2580	385	81	3100	67		18
2V1856 ###	Prepared for Gr.2 hydraulic motor				☑	400	☑	☑	/		19

☑ Contattare EMMEGI Contact EMMEGI

Diagramma rendimento Performance diagram

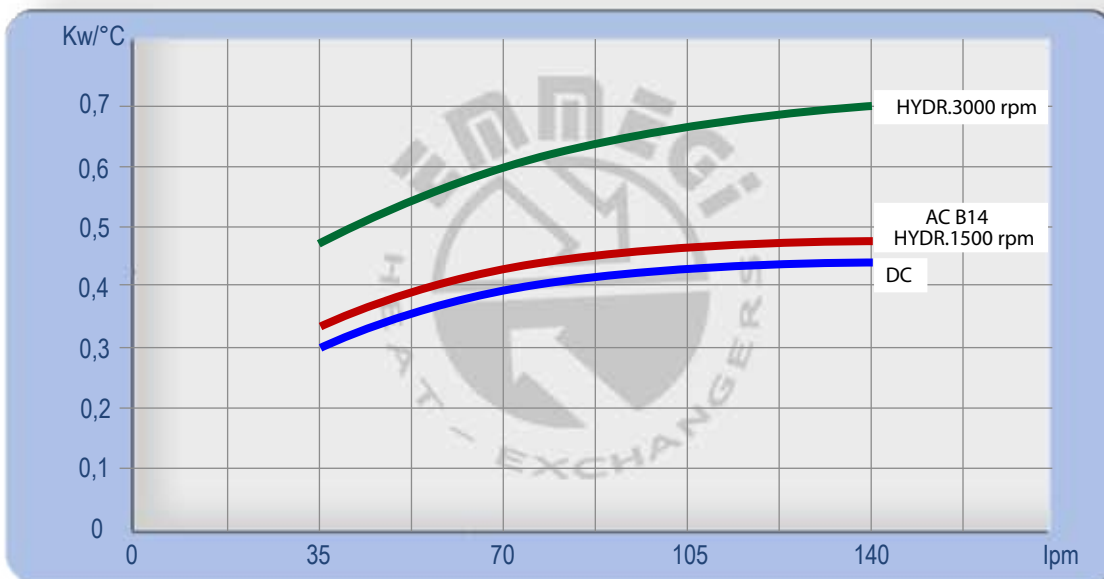

Perdite di carico Pressure drop (ISO VG 32)

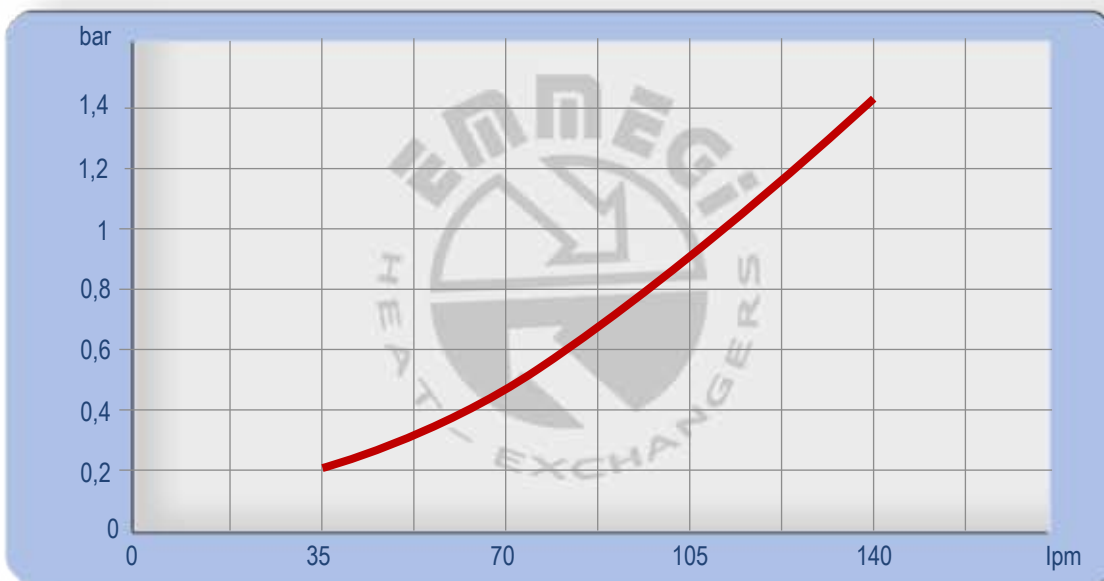

Fattore di correzione - F - (perdite di carico) Correction factor - F - (Pressure drop)

cst	10	15	20	30	40	50	60	80	100	200	300
F	0,5	0,65	0,77	1	1,2	1,4	1,6	1,9	2,1	3,3	4,3

Dimensioni Dimensions

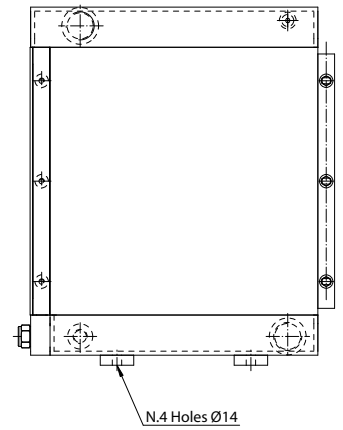
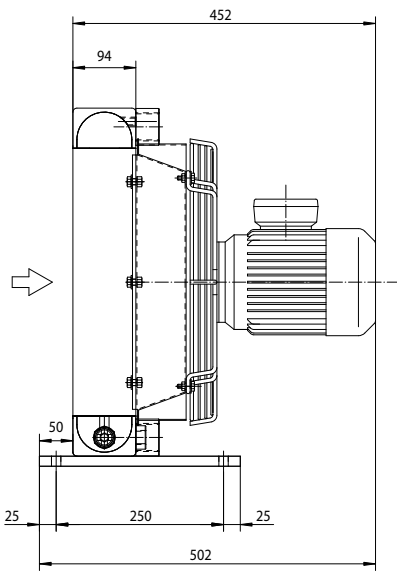
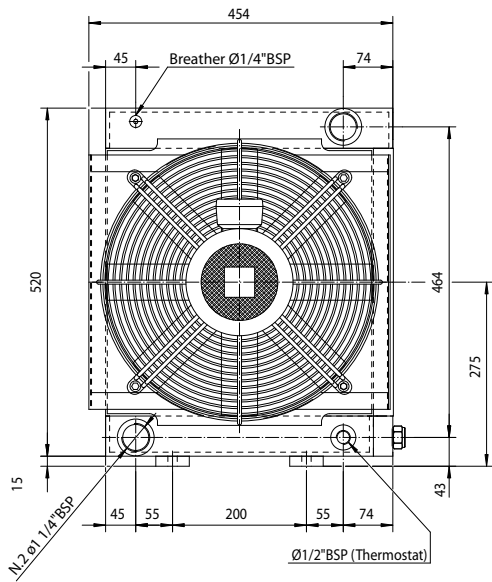

P/N 2V2403###

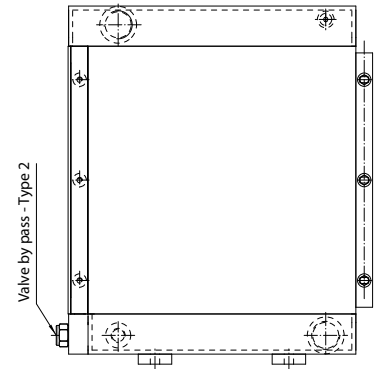
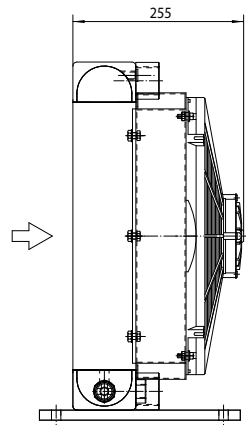
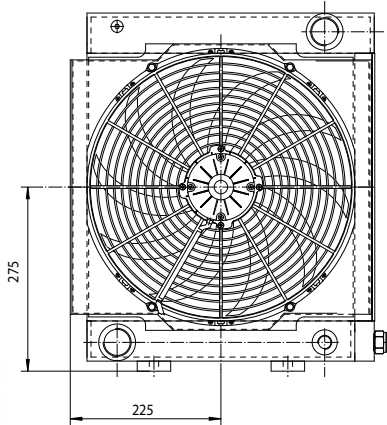

P/N 2V2412###
P/N 2V2424###

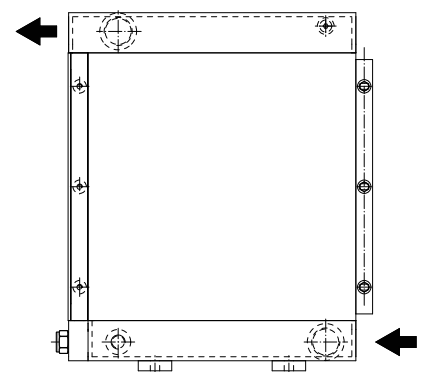
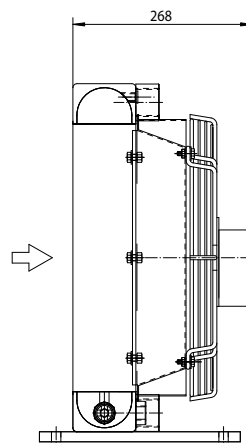
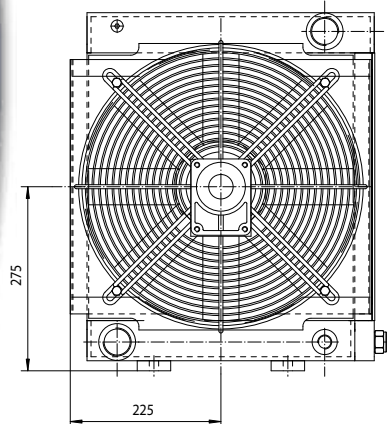

P/N 2V2456###

Le dimensioni di ingombro e le caratteristiche tecniche non sono impegnative
Over-all dimensions and technical characteristic are not binding

Dati tecnici Technical Data



HPV 24
47 NPH

P/N	V	Hz	kW	A	rpm	ø Fan	dB(A)	(m³/h)	IP	lt	Kg
2V2403 ###	230-400 B14 AC	50	0,55	2,58-1,49	1391	400	79	2800	55	2,9	28
	280-480 B14 AC	60	0,66	2,56-1,49	1669		☑				☑
2V2412 ###	12 DC	/	0,187	15,6	2350	385	77	2100	67		22
2V2424 ###	24 DC	/	0,170	7,1	2580	305	80	2250	67		22
2V2456 ###	Prepared for Gr.2 hydraulic motor				☑	400	☑	☑	/		23

☑ Contattare EMMEGI Contact EMMEGI

Diagramma rendimento Performance diagram

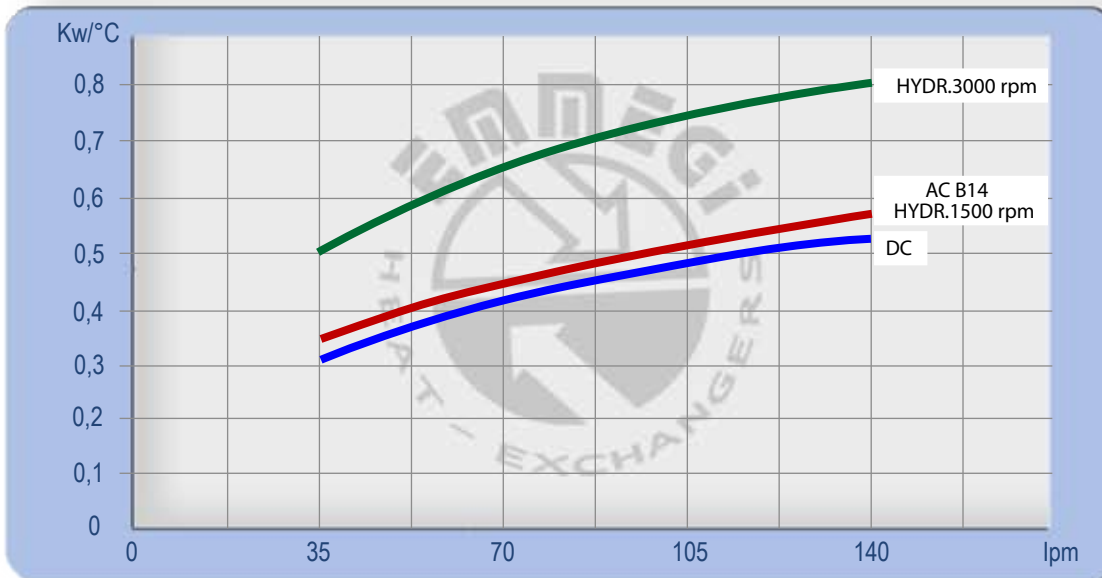

Perdite di carico Pressure drop (ISO VG 32)

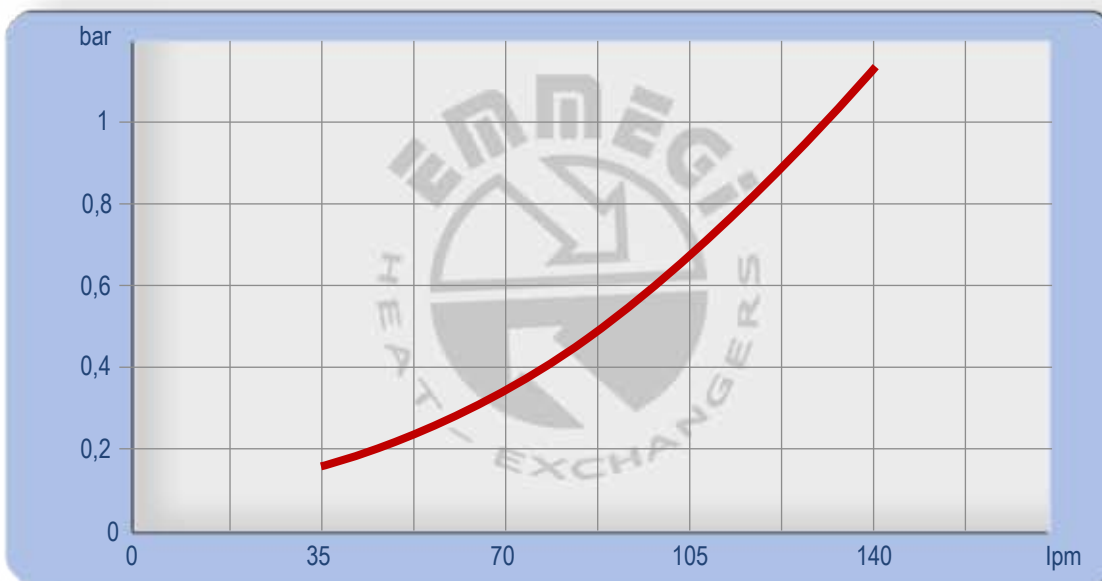

Fattore di correzione - F - (perdite di carico) Correction factor - F - (Pressure drop)

cst	10	15	20	30	40	50	60	80	100	200	300
F	0,5	0,65	0,77	1	1,2	1,4	1,6	1,9	2,1	3,3	4,3

Dimensioni Dimensions

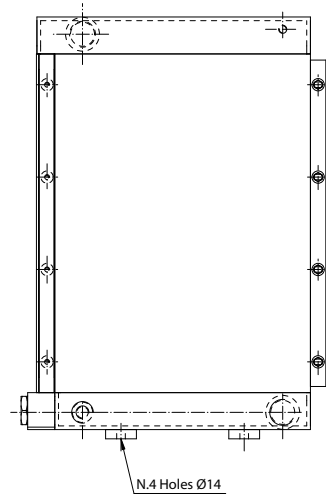
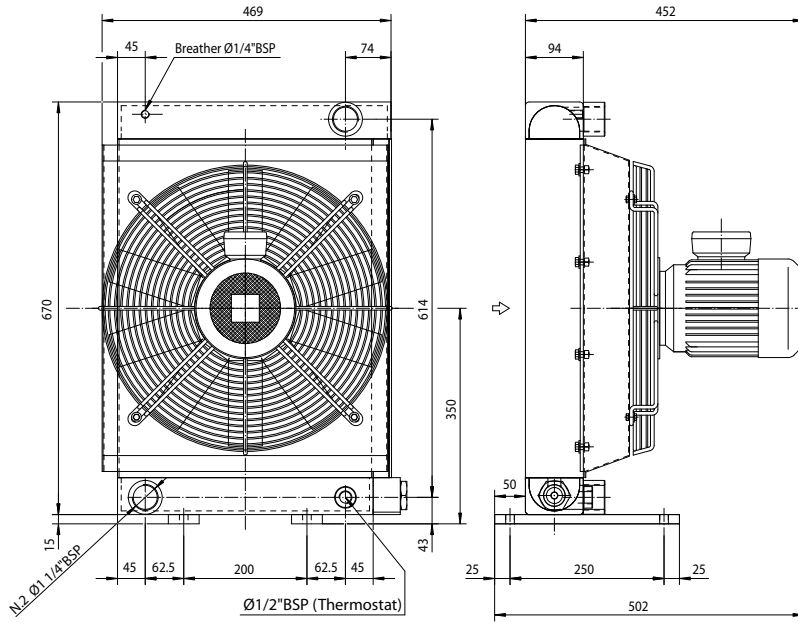

P/N 2V3003###

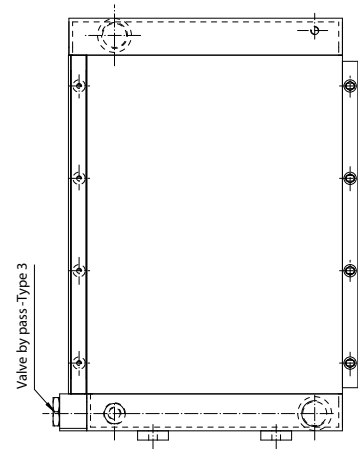
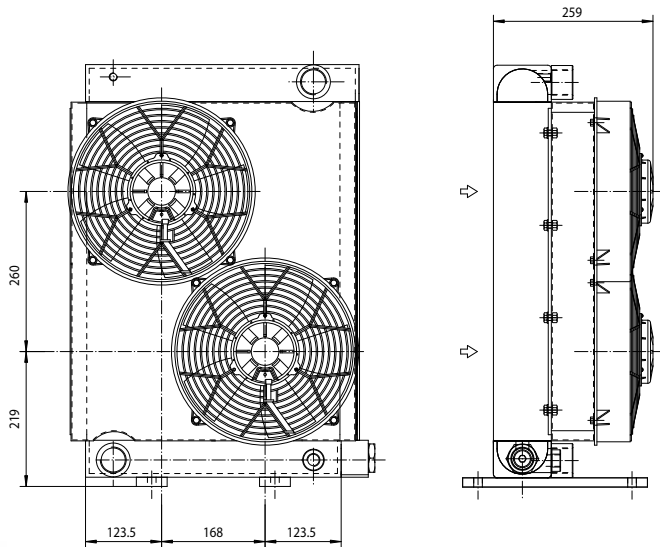

P/N 2V3012###
P/N 2V3024###

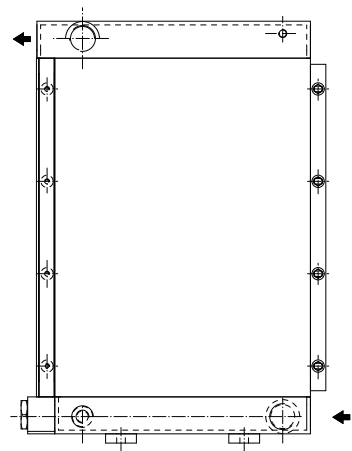
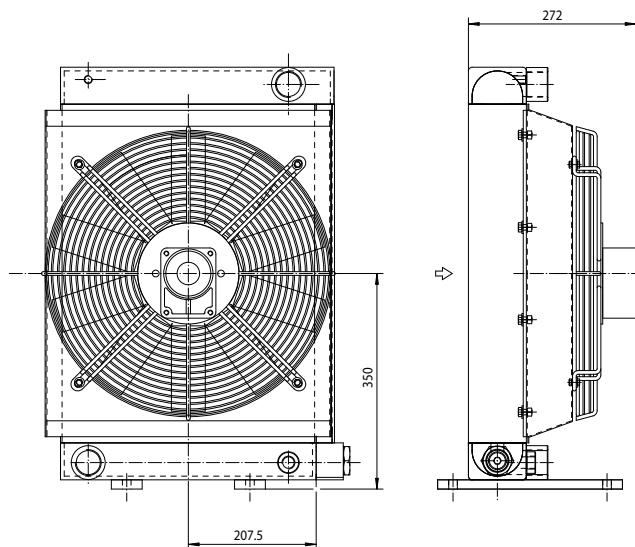

P/N 2V3056###

Le dimensioni di ingombro e le caratteristiche tecniche non sono impegnative
Over-all dimensions and technical characteristic are not binding

HPV 30

Dati tecnici Technical Data



HPV 30
HI

P/N	V	Hz	kW	A	rpm	ø Fan	dB(A)	(m³/h)	IP	lt	Kg
2V3003 ###	230-400 B14 AC	50	0,75	3,46-1,90	1394	450	82	4000	55	6,8	37
	280-480 B14 AC	60	0,90	3,41-1,99	1673						
2V3012 ###	12 DC	/	0,115	9,58	2530	280	74	1550	67		32
2V3024 ###	24 DC	/	0,125	5,20	2900	280	78	1700	67		32
2V3056 ###	Prepared for Gr.2 hydraulic motor					450			/	35	

Per il 12-24V i dati sono riferiti al singolo ventilatore For 12-24V the data refers to each ventilator

Contattare EMMEGI Contact EMMEGI

Diagramma rendimento Performance diagram

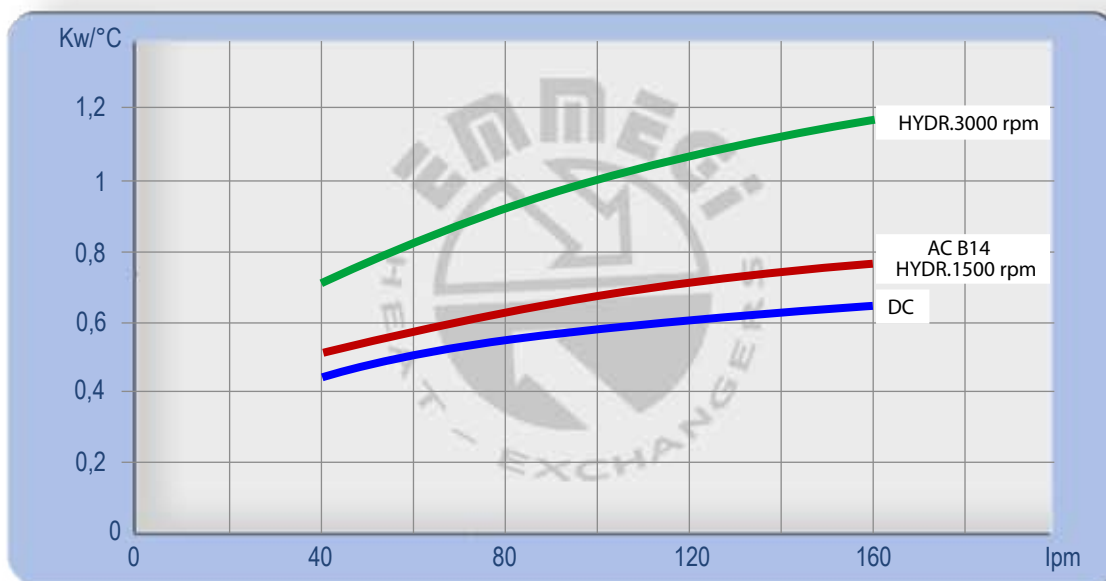

Perdite di carico Pressure drop (ISO VG 32)

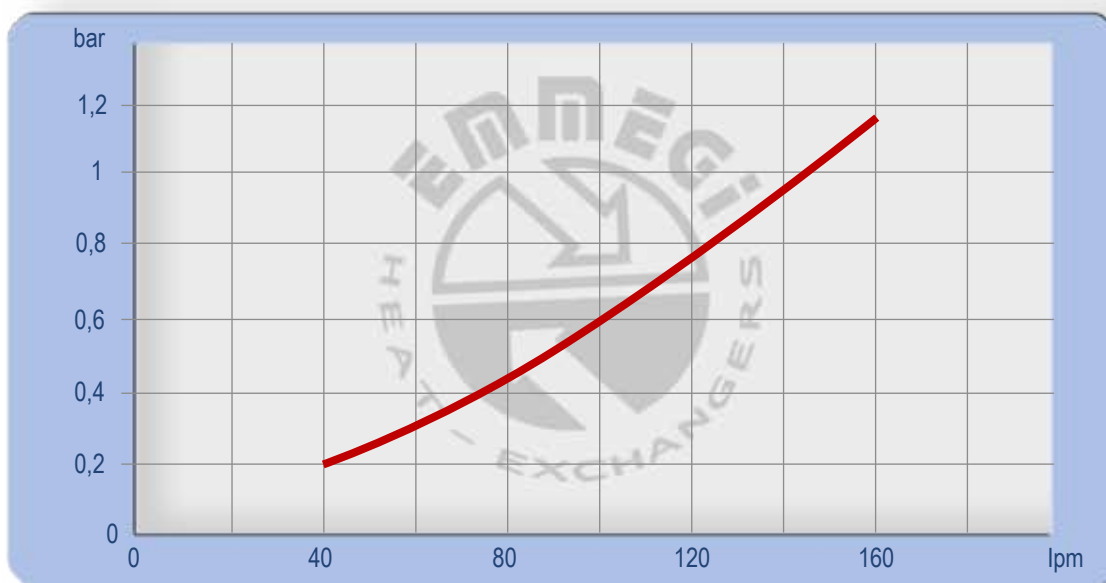

Fattore di correzione - F - (perdite di carico) Correction factor - F - (Pressure drop)

cst	10	15	20	30	40	50	60	80	100	200	300
F	0,5	0,65	0,77	1	1,2	1,4	1,6	1,9	2,1	3,3	4,3

Dimensioni Dimensions

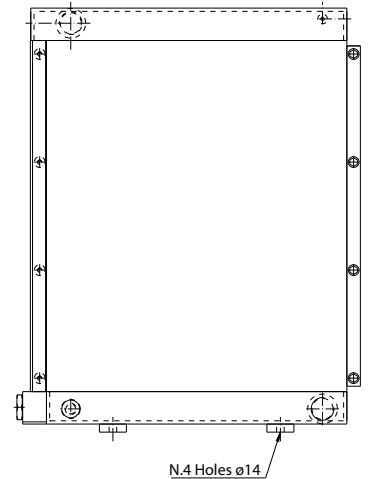
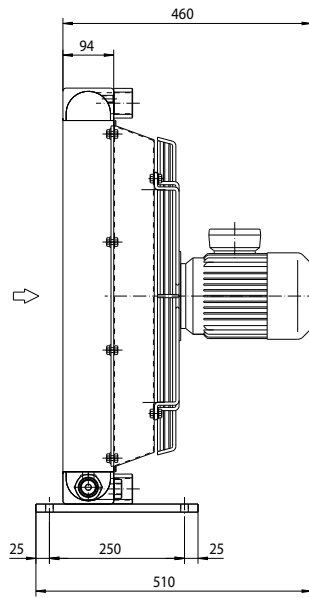
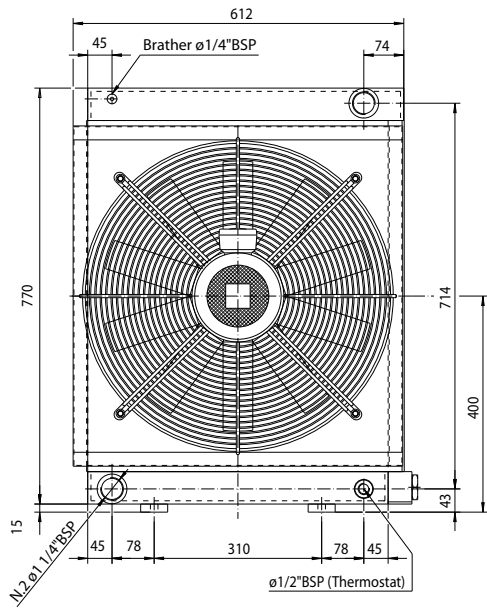

P/N 2V3603###

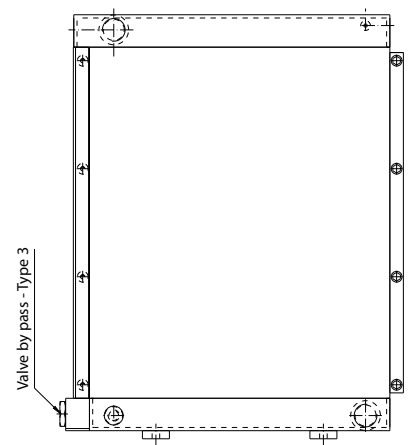
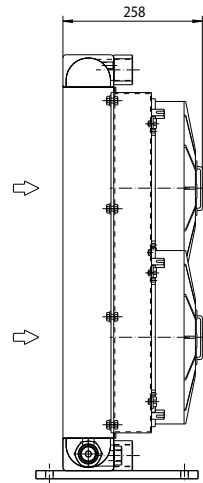
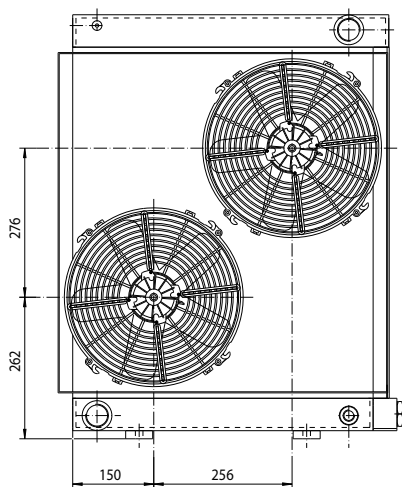

P/N 2V3612###
P/N 2V3624###

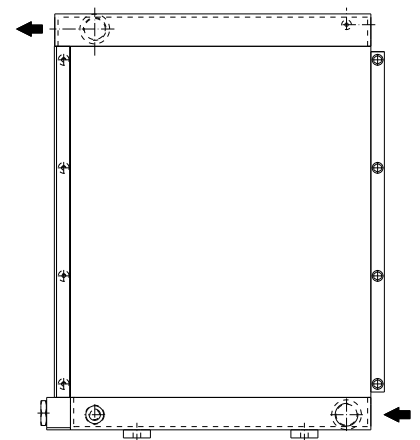
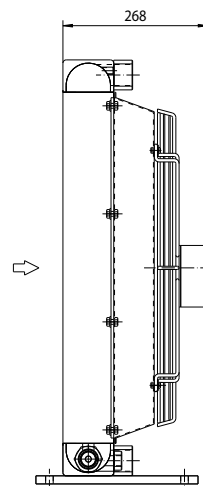
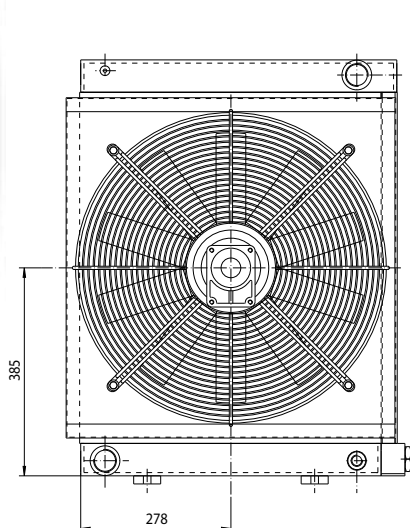

P/N 2V3656###

Le dimensioni di ingombro e le caratteristiche tecniche non sono impegnative
Over-all dimensions and technical characteristic are not binding

Dati tecnici Technical Data



HPV 36
HI

P/N	V	Hz	kW	A	rpm	∅ Fan	dB(A)	(m³/h)	IP	lt	Kg
2V3603 ###	230-400 B14 AC	50	1,1	4,35-2,50	1378	500	82	5650	55	9,4	60
	280-480 B14 AC	60	1,32	4,29-2,50	1654		☑				
2V3612 ###	12 DC	/	0,160	13,30	2560	305	83	2100	67		50
2V3624 ###	24 DC	/	0,177	7,35	3000	305	84	2400	67		50
2V3656 ###	Prepared for Gr.2 hydraulic motor				☑	450	☑	☑	/		52

Per il 12-24V i dati sono riferiti al singolo ventilatore For 12-24V the data refers to each ventilator

☑ Contattare EMMEGI Contact EMMEGI

Diagramma rendimento Performance diagram

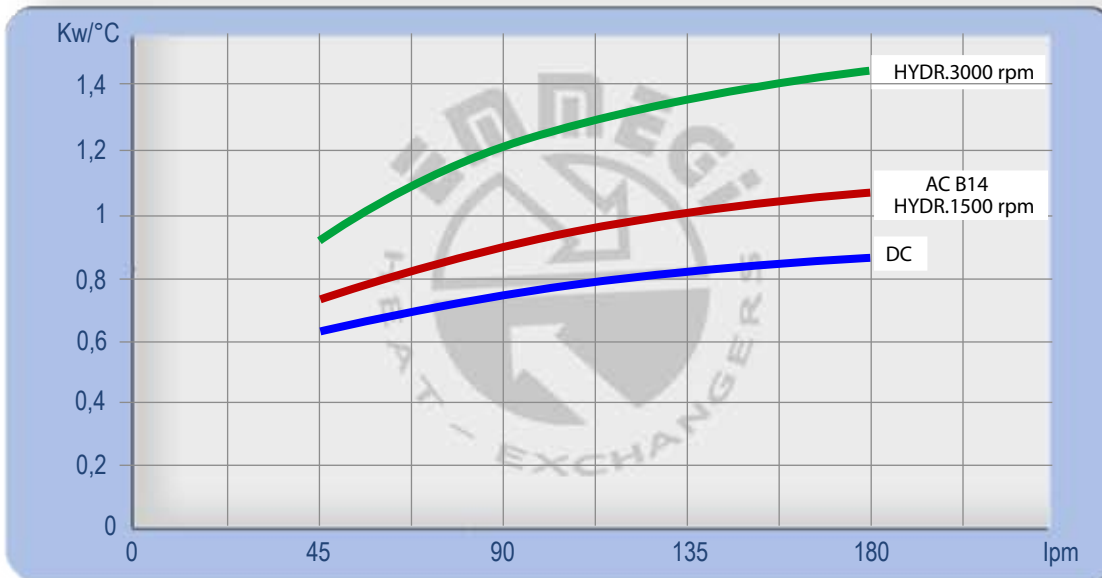

Perdite di carico Pressure drop (32 CTS)

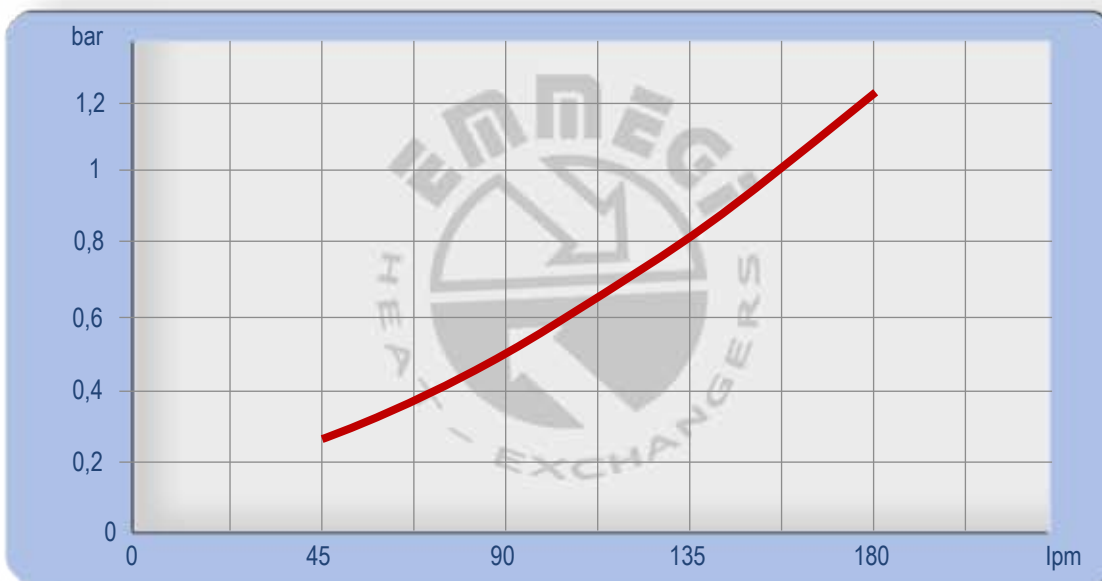

Fattore di correzione - F -(perdite di carico) Correction factor - F - (Pressure drop)

cst	10	15	20	30	40	50	60	80	100	200	300
F	0,5	0,65	0,77	1	1,2	1,4	1,6	1,9	2,1	3,3	4,3

Dimensioni Dimensions

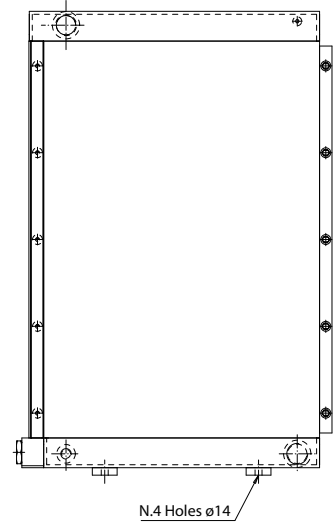
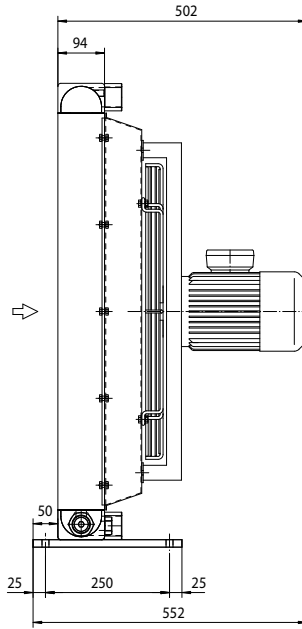
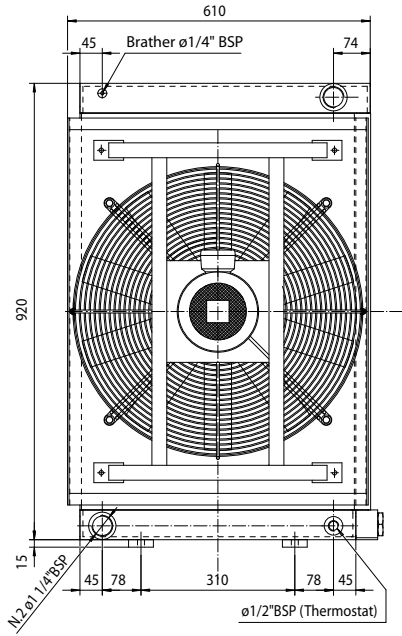

P/N 2V4203###

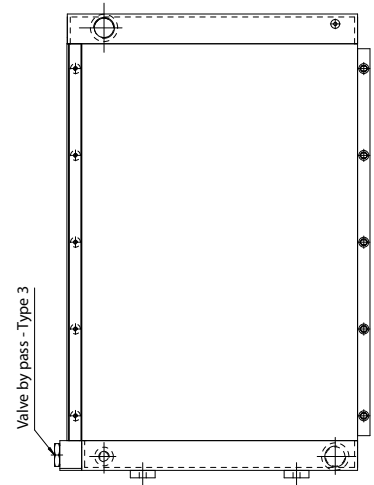
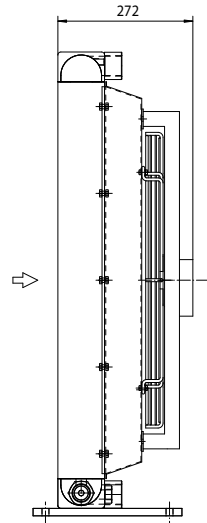
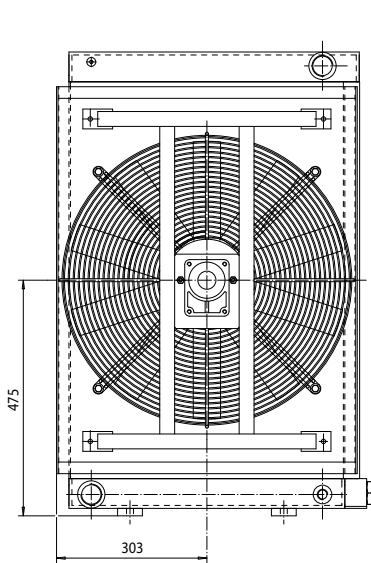

P/N 2V4256###

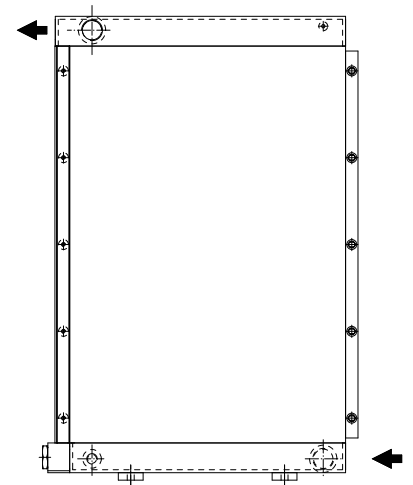
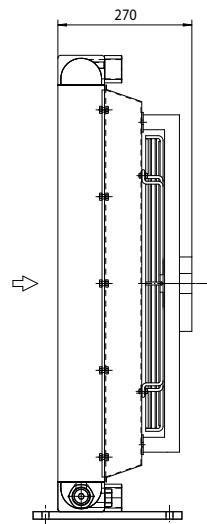
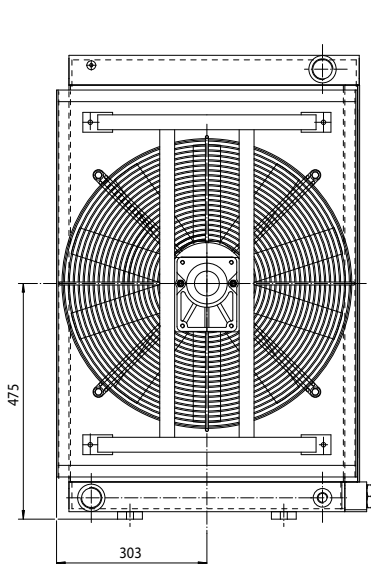

P/N 2V4258###

Le dimensioni di ingombro e le caratteristiche tecniche non sono impegnative
Over-all dimensions and technical characteristic are not binding

HPV 42

Dati tecnici Technical Data



HPV 42
A1H1

P/N	V	Hz	kW	A	rpm	ø Fan	dB(A)	(m³/h)	IP	lt	Kg
2V4203 ###	230-400 B14 AC	50	1,1	4,35-2,50	1378	560	84	7550	55	10,6	65
	280-480 B14 AC	60	1,32	4,29-2,50	1654		☒	☒			
2V4256 ###	Prepared for Gr.2 hydraulic motor				☒	☒	☒	☒	/		
2V4258 ###	Prepared for Gr.3 hydraulic motor				☒	☒	☒	☒	/	58	

☒ Contattare EMMEGI Contact EMMEGI

Diagramma rendimento Performance diagram

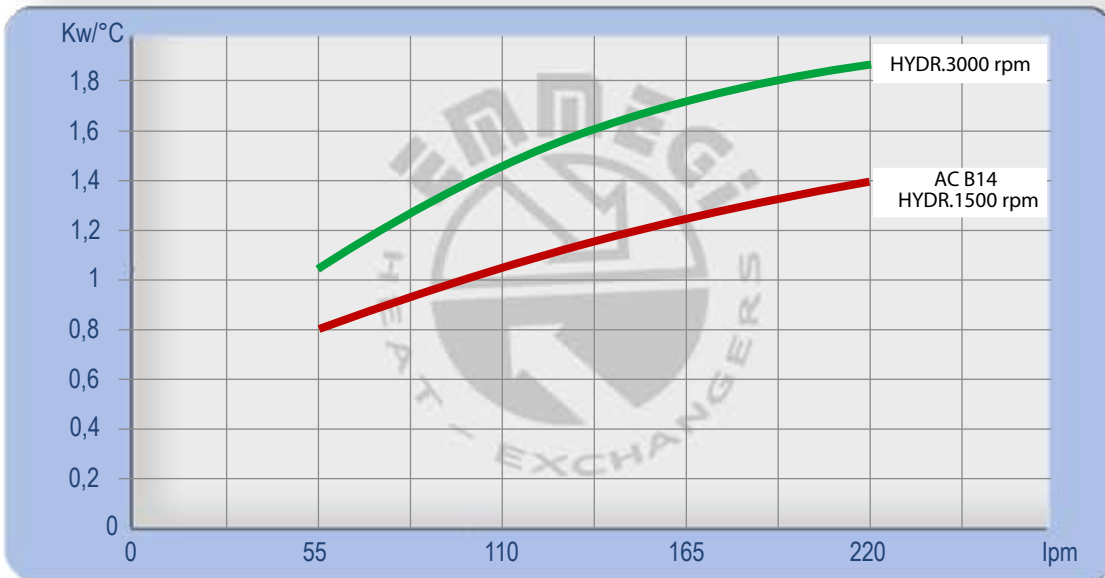

Perdite di carico Pressure drop (ISO VG 32)

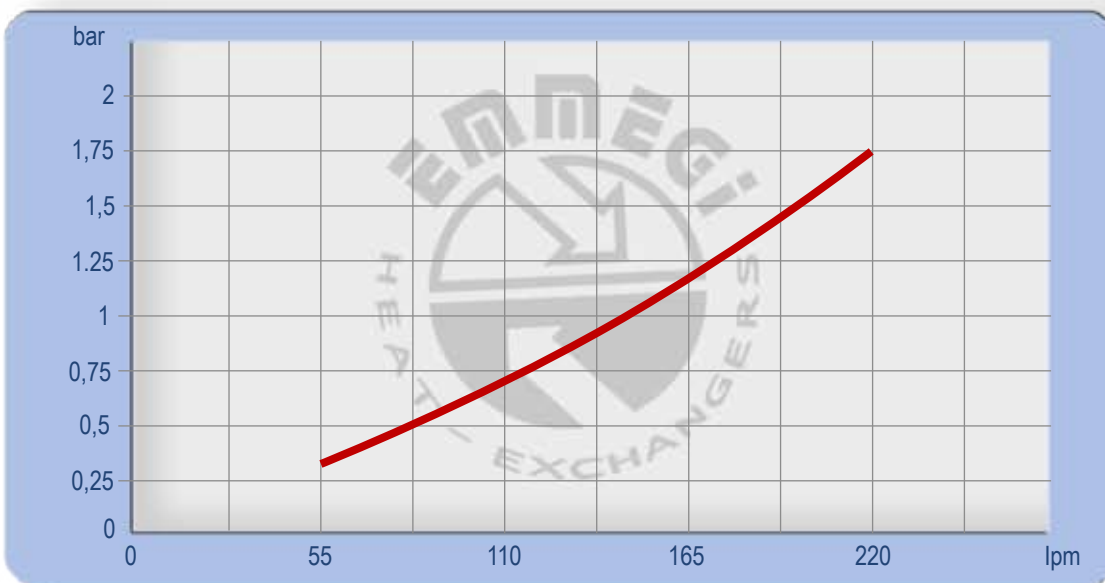

Fattore di correzione - F - (perdite di carico) Correction factor - F - (Pressure drop)

cst	10	15	20	30	40	50	60	80	100	200	300
F	0,5	0,65	0,77	1	1,2	1,4	1,6	1,9	2,1	3,3	4,3

Dimensioni Dimensions

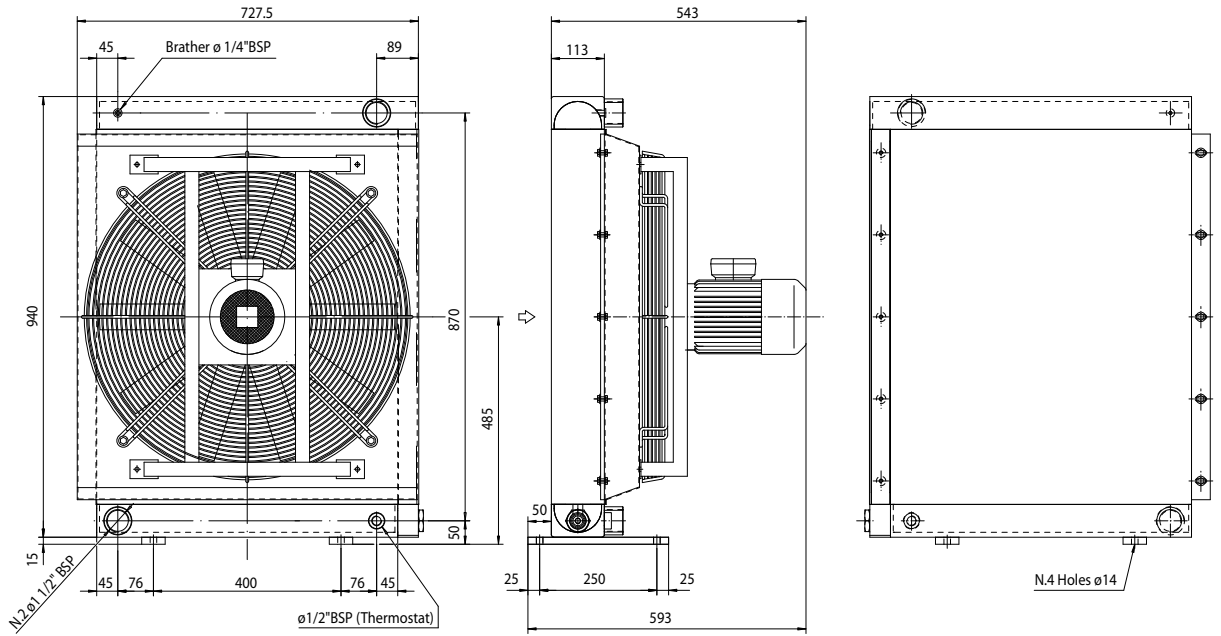

P/N 2V5003###

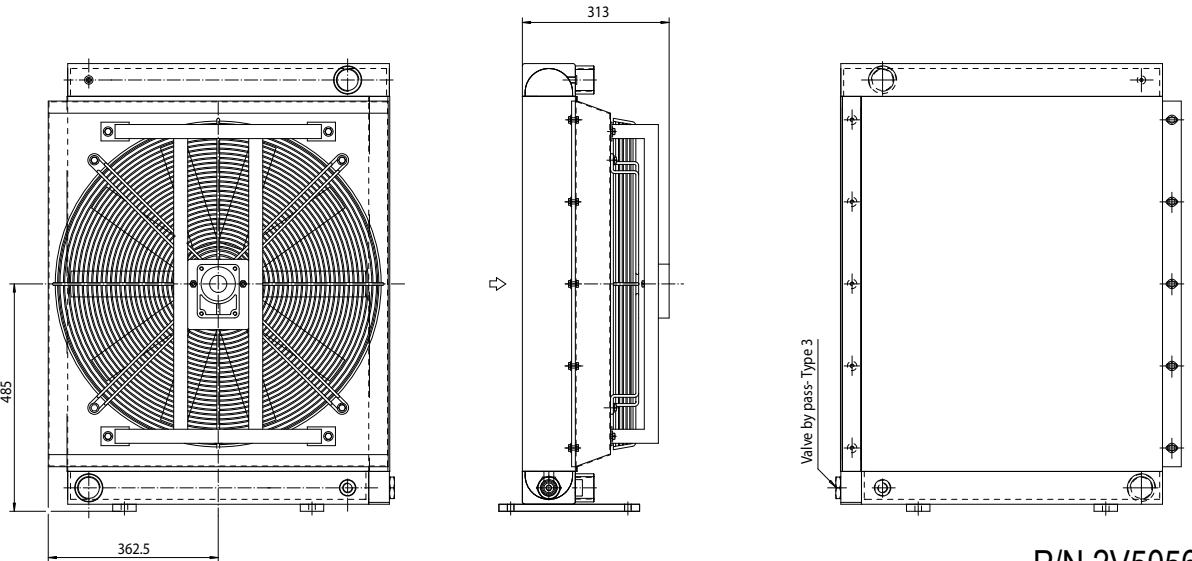

P/N 2V5056###

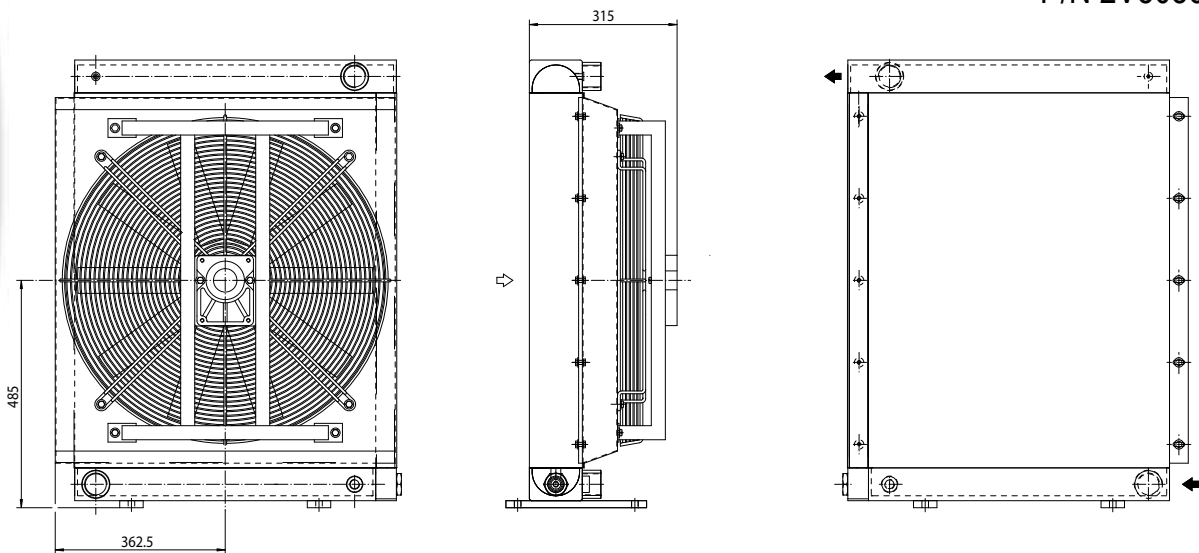

P/N 2V5058###

Le dimensioni di ingombro e le caratteristiche tecniche non sono impegnative
Over-all dimensions and technical characteristic are not binding

HPV 50

Dati tecnici Technical Data



HPV 50
AC B14

P/N	V	Hz	kW	A	rpm	ø Fan	dB(A)	(m³/h)	IP	lt	Kg
2V5003 ###	230-400 B14 AC	50	1,1	4,77-2,74	915	630	80	7550	55	14,2	90
	280-480 B14 AC	60	1,32	4,70-2,74	1098		☑	☑			
2V5056 ###	Prepared for Gr.2 hydraulic motor				☑	630	☑	☑	/		83
2V5058 ###	Prepared for Gr.3 hydraulic motor				☑	630	☑	☑	/		83

☑ Contattare EMMEGI Contact EMMEGI

Diagramma rendimento Performance diagram

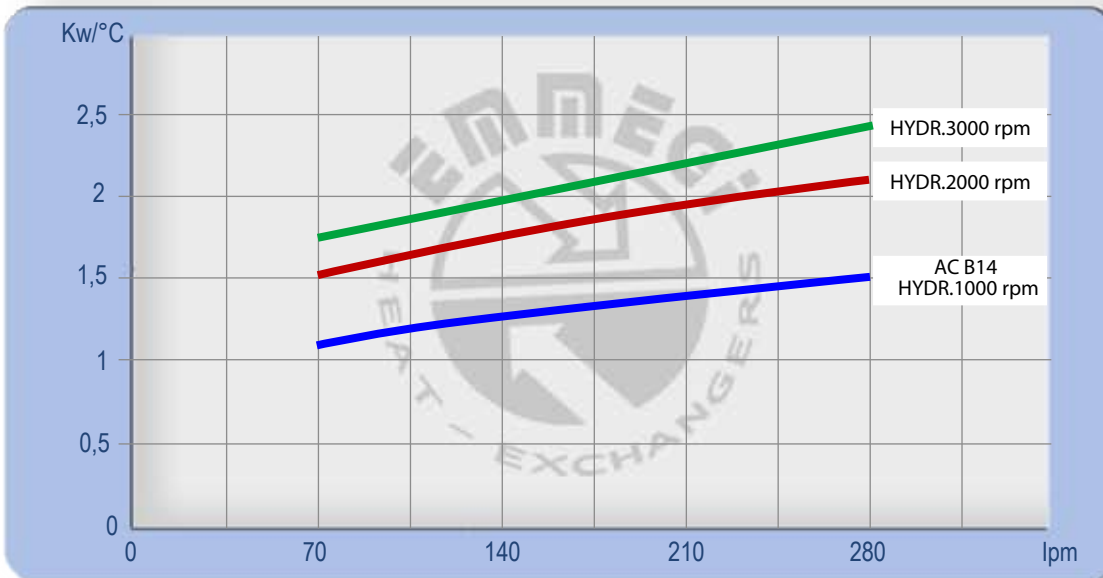

Perdite di carico Pressure drop (ISO VG 32)

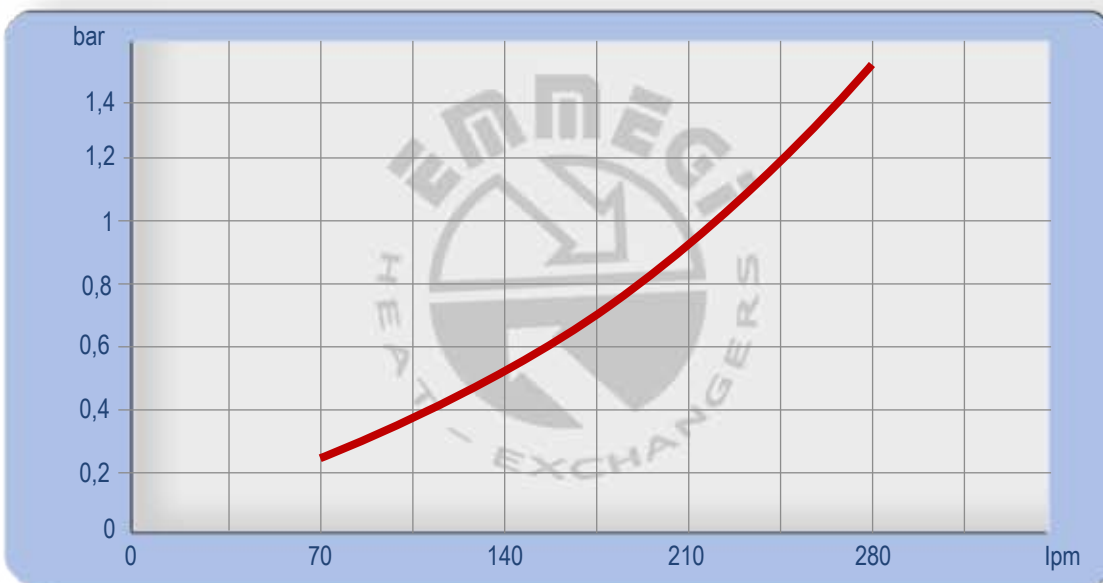

Fattore di correzione - F - (perdite di carico) Correction factor - F - (Pressure drop)

cst	10	15	20	30	40	50	60	80	100	200	300
F	0,5	0,65	0,77	1	1,2	1,4	1,6	1,9	2,1	3,3	4,3

Dimensioni Dimensions

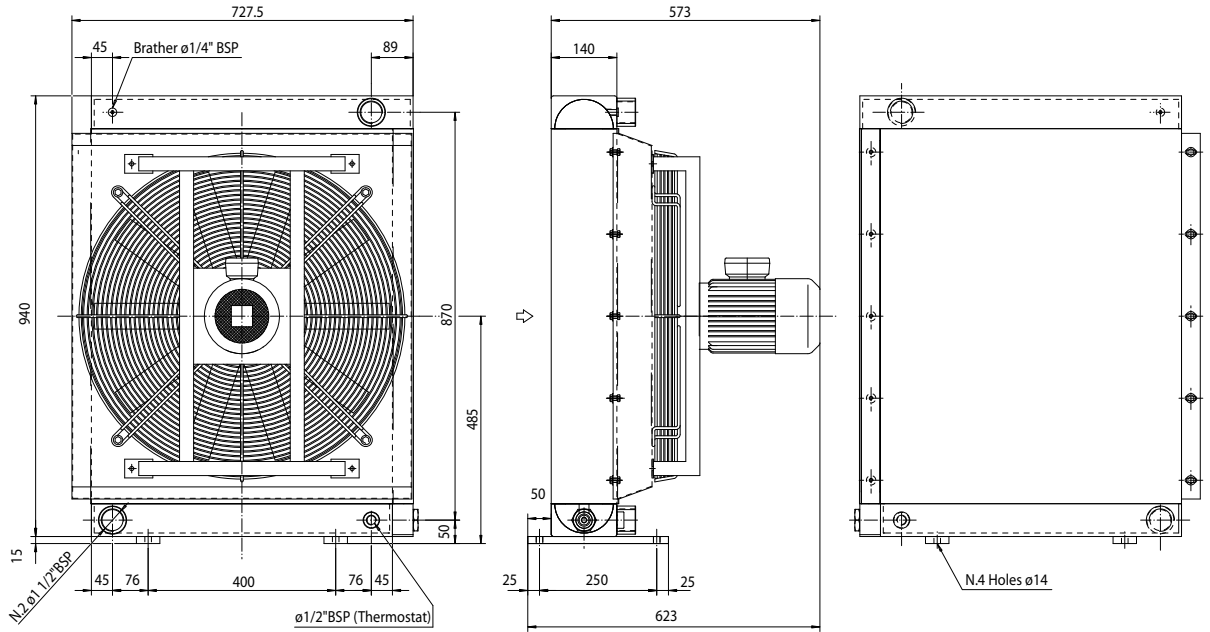

P/N 2V5203###

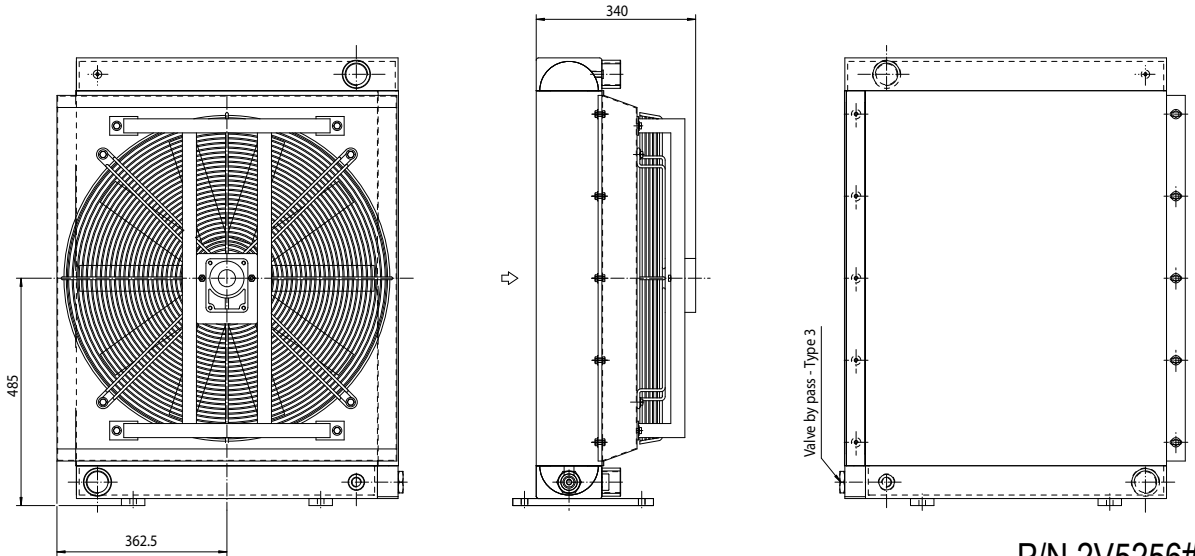

P/N 2V5256###

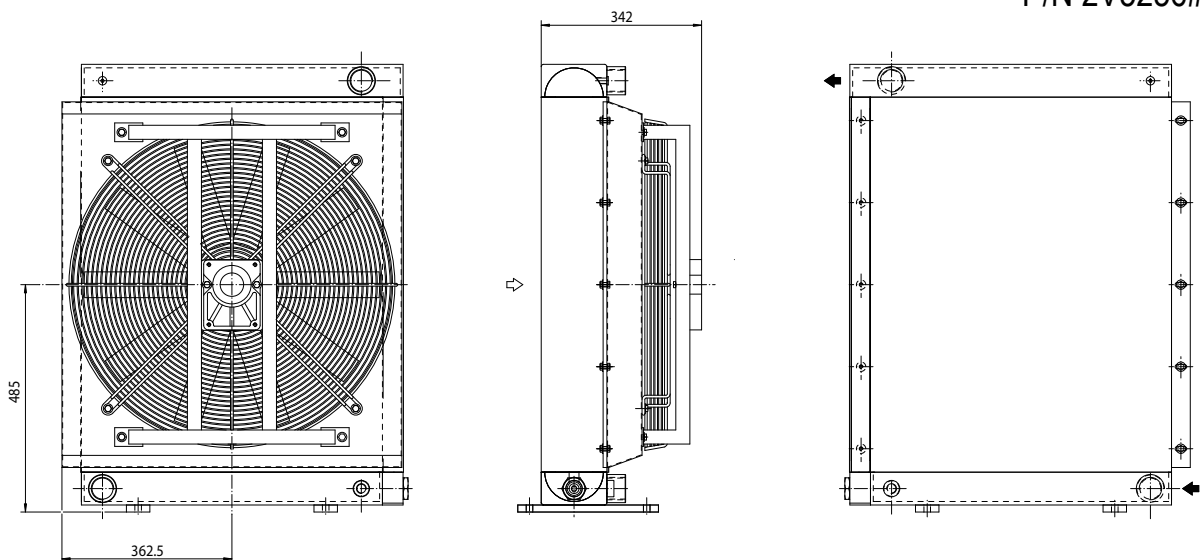

P/N 2V5258###

Le dimensioni di ingombro e le caratteristiche tecniche non sono impegnative
Over-all dimensions and technical characteristic are not binding

Dati tecnici Technical Data



HPV 52
APIH

P/N	V	Hz	kW	A	rpm	ø Fan	dB(A)	(m³/h)	IP	lt	Kg
2V5203 ###	230-400 B14 AC	50	1,1	4,77-2,74	915	630	80	7050	55	17,7	95
	280-480 B14 AC	60	1,32	4,70-2,74	1098		☒	☒			
2V5256 ###	Prepared for Gr.2 hydraulic motor				☒	630	☒	☒	/		89
2V5258 ###	Prepared for Gr.3 hydraulic motor				☒	630	☒	☒	/		89

☒ Contattare EMMEGI Contact EMMEGI

Diagramma rendimento Performance diagram

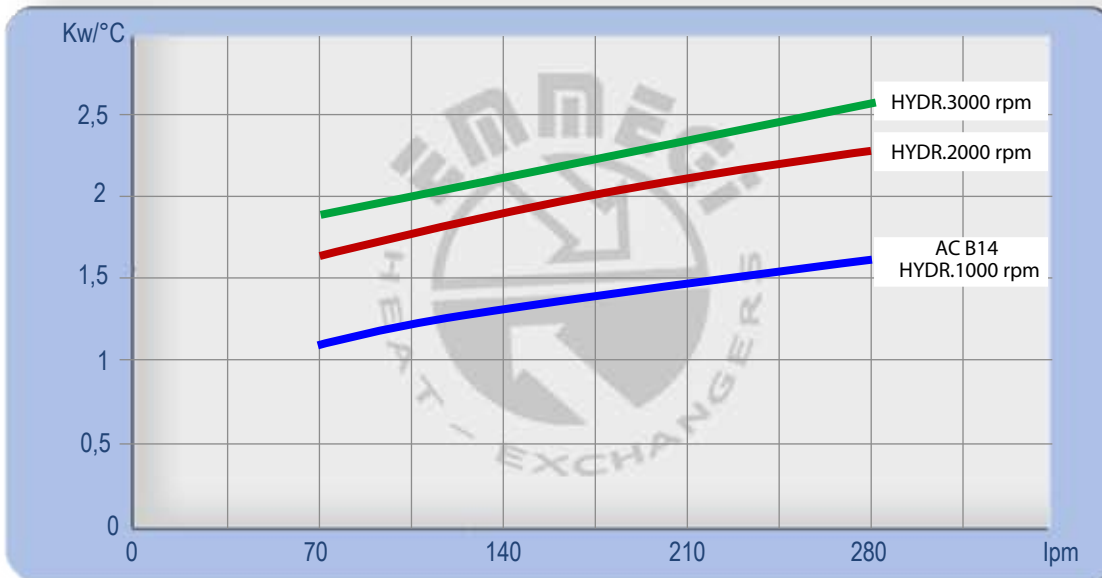

Perdite di carico Pressure drop (32 CST)

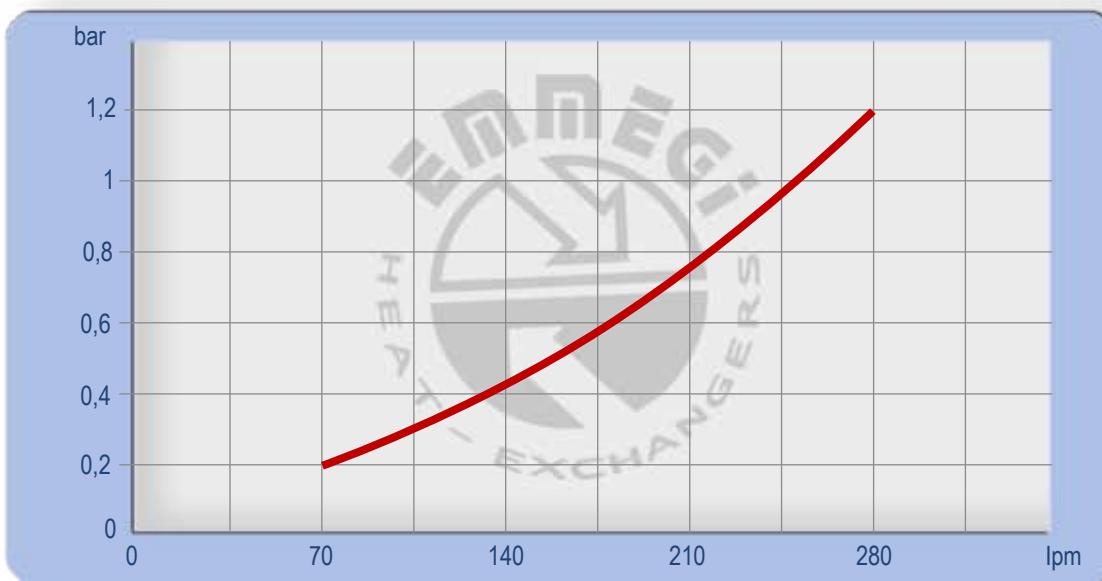

Fattore di correzione - F - (perdite di carico) Correction factor - F - (Pressure drop)

cst	10	15	20	30	40	50	60	80	100	200	300
F	0,5	0,65	0,77	1	1,2	1,4	1,6	1,9	2,1	3,3	4,3

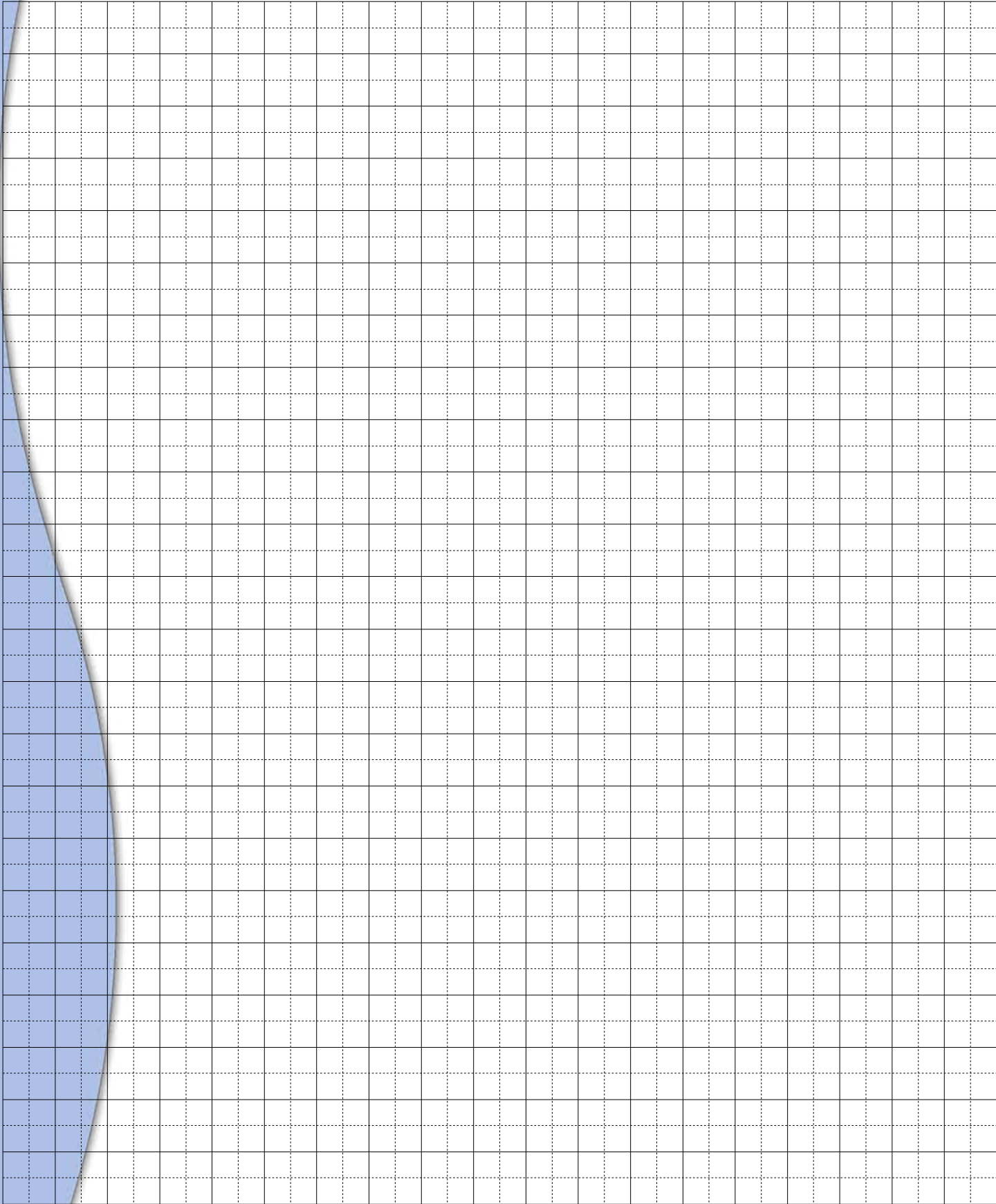

Alla ricerca di un continuo miglioramento del prodotto, EMMEGI S.p.A. si riserva il diritto di approntare modifiche ai dati e alle caratteristiche illustrate nel catalogo.

La riproduzione, anche parziale, del presente catalogo è vietata ai termini di legge.

Questo catalogo sostituisce tutti i precedenti.

As EMMEGI S.p.A. are always investigating methods of improving products and introducing new technology, we reserve the right to modify without notice the data features shown in this catalogue.

The reproduction, even partial of this catalogue is forbidden by law.

This catalogue replace all the previous one.

USA

EMMEGI HEAT EXCHANGERS Inc.

(Main Office and Manufacturing)
3606 E. Southern Ave. Suite 2
Phoenix, AZ 85040 USA
Ph. +1 602 438 7101
Fax + 1 602 438 7127
<http://www.emmegiinc.com>
sales@emmegiinc.com

CHINA

EMMEGI HEAT EXCHANGERS

(Beijing) Co.,Ltd.
Unit 706,7/ F. Building A, China
Foreign Language Mansion,
89 West, 3 rd Ring (N) Road,
Haidian District,Beijing,
PR.China,Post code: 100089
Ph. + 86 10 88820971- Fax + 86 10 88820972
<http://www.emmegi-heat-exchangers.com>
stefano@emmegi-heat-exchangers.com

SWEDEN/FINLAND

EMMEGI HEAT EXCHANGERS

NORDIC AB.
Box 1136
262 22 ANGELHOLM
Visitors: Nybrovagen 4
Ph. + 46 (0) 431- 415096
Fax + 46 (0) 431- 415099
<http://www.emmegi-heat-exchangers.com>
info.nordic@emmegi-heat-exchangers.com

UK

EMMEGI HEAT EXCHANGERS UK LTD

Unit 820 Jupiter Court, Meteor Business Park
Cheltenham Road
Gloucester
GL2 9QW
Ph. + 44 01452 540130
Mob. + 44 07825 278394
<http://www.emmegi.co.uk>
jquigley@emmegi.co.uk

TURKEY

EMMEGI HEAT EXCHANGERS

Termal Sistemler Sanayi ve Ticaret Ltd.Şti
8229/2 Sok. No: 12 Odin iş merkezi
Çiğli- İzmir / Turkey
Ph. +90 530 3927636
Fax. +90 850 2244594
<http://www.emmegi-turkey.com>
kudret@emmegi-turkey.com

ASIA / PACIFIC

EMMEGI HEAT EXCHANGERS Ltd

Unit 17.9/ F.Corporation Park,
11 On Lai Street, Siu Lek Yuen,
Shatin, Hong Kong
Ph. + 852-26032487- Fax + 852-26032119
<http://www.emmegi-heat-exchangers.com>
emmegi@biznetvigator.com

GERMANY

EMMEGI GmbH

Philipp-Reis-Straße 2
41516 Grevenbroich-Kapellen
Ph. +49 02182-570 18-0
Fax +49 02182-570 18-29
vertrieb@emmegi-gmbh.de
<http://www.emmegi-gmbh.de>

SLOVAKIA

EMMEGI HEAT EXCHANGERS s.r.o.

Ul. M.Razusa 1
95514 Topolcany
Ph. + 421 385320739
Fax +421 385320742
<http://www.emmegi-heat-exchangers.com>
sro@emmegi-heat-exchangers.com

INDIA

EMMEGI India Private Limited

G-221, Sector 3, DSIIDC Bawana
Delhi – 110039, INDIA
+91 11 27761242, 27762018
<http://www.emmegi-heat-exchangers.com>
anil@emmegi-heat-exchangers.com

ITALIA

EMMEGI S.p.A.

Via Newton,52 - Zona Industriale
20062 Cassano d'Adda (MI) - Italy
Tel. +39 0363 360236 - Fax + 39 0363 360230
<http://www.emmegi-heat-exchangers.com>
info@emmegi-heat-exchangers.com

