



---

**POMPE E MOTORI A PISTONI ASSIALI  
AD ASSE INCLINATO**

***BENT AXIS AXIAL PISTON  
PUMPS AND MOTORS***

**AXIALKOLBENPUMPEN-MOTOREN**

**HM PF  
45**

398SBF0033A01

# HM PF

## POMPE A PISTONI ASSIALI PER CIRCUITO APERTO A CILINDRATA FISSA OPEN CIRCUIT AXIAL FIXED-DISPLACEMENT PISTON PUMPS AXIALKOLBENPUMPEN FÜR DEN OFFENEN KREISLAUF

Le pompe a pistoni assiali serie HM PF sono a cilindrata fissa del tipo ad asse inclinato e sono stati concepiti per operare in circuito aperto.

Il sistema è stato progettato in modo da ottenere un angolo di inclinazione di 40° dei pompanti rispetto all'asse dell'albero uscente.

Tale geometria permette:

- elevata coppia di spunto
- elevata efficienza volumetrica e meccanica
- elevate pressioni massime

*Axial piston pumps series HM PF are fixed displacement and bent axis and have been designed to work both in an open circuit.*

*The system has been designed in order to obtain 40° angle of inclination of the pumps with respect to the axle of the outgoing shaft.*

*This geometry allows:*

- high static torque
- high volumetric and mechanical efficiency
- high maximum pressures

Die Axialkolbenpumpen der Baureihe HM PF sind Schrägscheibenmotoren mit konstantem Verdrängungsvolumen und können sowohl im offenen Kreislauf arbeiten.

Die Schrägachsenmotoren wurden so konstruiert, daß sie einen großen Schwenkwinkel von 40° haben.

Dies ermöglicht:

- Höheres Anlaufmoment
- Gute mechanisch hydraulische und volumetrische Wirkungsgrade
- Hohe Enddrehzahl
- Hohe Betriebsdrücke

## HM PF 45

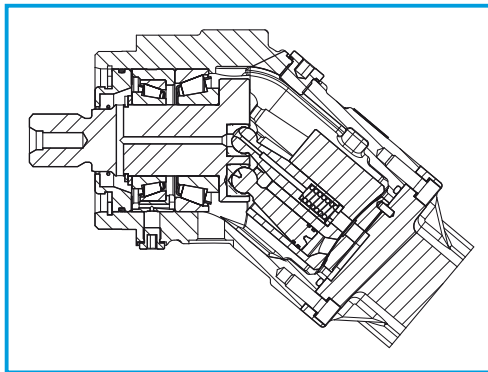
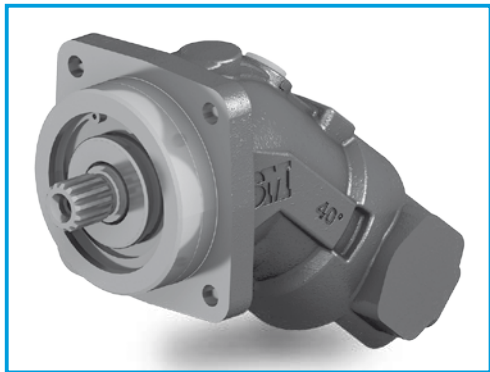

### DATI TECNICI TECHNICAL DATA TECHNISCHE MERKMALE

GRUPPO GROUP BAUREIHE	CILINDRATA TEORICA NOMINAL DISPLACEMENT FÖRDERVOLUMEN		PRESSIONE PRESSURE DRUCK		VELOCITÀ DI ROTAZIONE SPEED DREHZAHL		COPPIA TORQUE DREHMOMENT		MASSA WEIGHT GEWICHT		MOMENTO POLARE D'INERZIA INERTIAL MASS TRAGHEITSMOMENT		
	cm <sup>3</sup>	in <sup>3</sup>	CONTINUA CONTINUOUS DAUER	INTERMITTENTE INTERMITTENT INTERMITTIERENDER	PICCO PEAK SPITZEN	n <sub>max</sub> min <sup>-1</sup>	at 350 bar		kg	lbs	kg • m <sup>2</sup>		
HM PF	45	2,75	350	5075	400	5800	450	6525	2240	254	17,2	37,9	0,0024

La velocità massima ammissibile può essere incrementata aumentando la pressione in alimentazione (vedi grafico).

*By increase of the input pressure the max speed can be increased (see diagram).*

Die zulässige Höchstgeschwindigkeit kann gesteigert werden, indem der Versorgungsdruck erhöht wird (siehe graphische Abbildung).

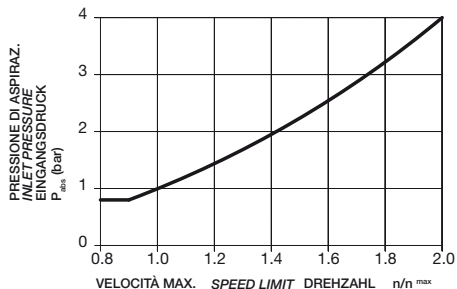



**DIMENSIONI  
SIZE  
ABMESSUNGEN**

**HM PF**

**I** FLANGIA ISO  
ISO FLANGE  
ISO FLANSCH

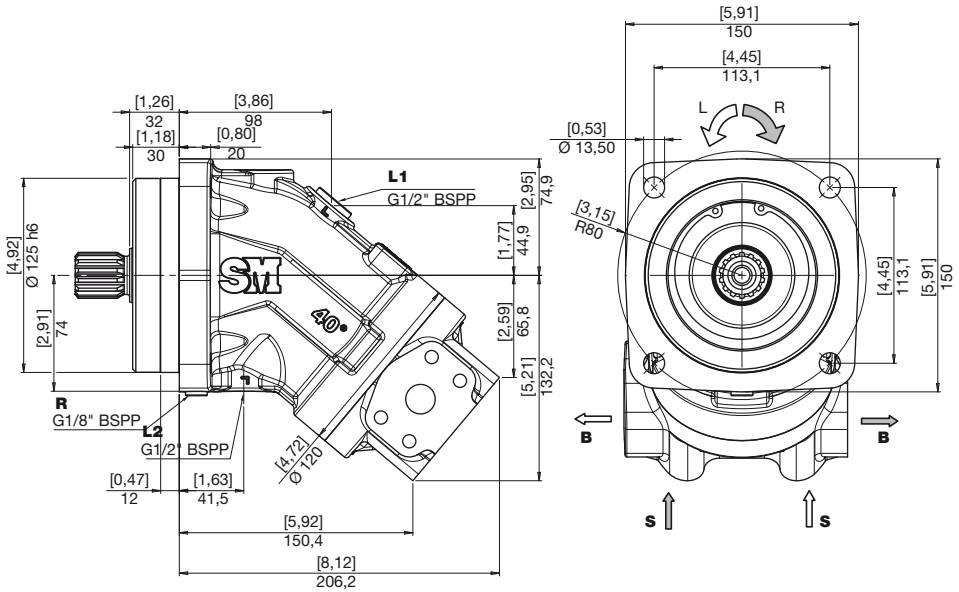

<b>L1</b>	Drenaggi Drain	<b>R</b>	Spurgo Air bleed
<b>L2</b>	Leckölanschluss		Entlüftung

<b>S</b>	Aspirazione Feeding pump inlet Ansaugöffnung	<b>B</b>	Mandata Outlet Ausgang
----------	--	----------	------------------------------

<b>L1</b>	Tappati Plugged
<b>R</b>	Verschlossen

**Z** COPPIA MAX  
MAX TORQUE  
MAX DREHMOMENT 730 N•m

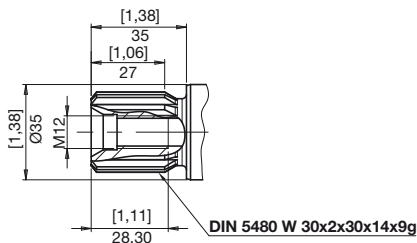

PRESSIONE CONTINUA  
CONTINUOUS PRESSURE  
NENNDRUCK

400 bar / 5800 psi

PRESSIONE DI PICCO  
PEAK PRESSURE  
HOCHSTDRUCK

450 bar / 6525 psi

**C** COPPIA MAX  
MAX TORQUE  
MAX DREHMOMENT 240 N•m

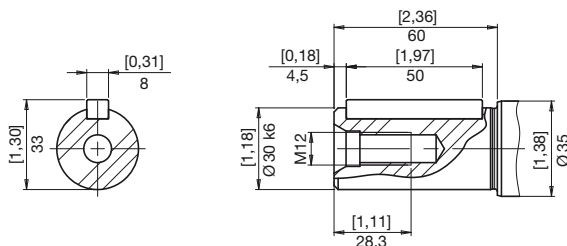

PRESSIONE CONTINUA  
CONTINUOUS PRESSURE  
NENNDRUCK

350 bar / 5075 psi

PRESSIONE DI PICCO  
PEAK PRESSURE  
HOCHSTDRUCK

400 bar / 5800 psi

Per applicazioni con carico radiale sull'albero motore (pignoni, cinghie trapezoidali), con albero tipo X e Y è consentita una pressione continua di 315 bar ( $P_{max} = 350$  bar).

With shaft type X and Y is allowed a continuous pressure of 315 bar ( $P_{max} = 350$  bar) for applications with radial load of the drive shaft (pinions, belts).

Bei Wellenende X und Y ist bei Abtrieben mit Querkraftbelastung der Triebwelle (Ritzel, Keilriemen) ein Nenndruck von 315 bar zulässig ( $p_{max} = 350$  bar).



**DISTRIBUTORI  
PORT PLATES  
ANSCHLUSSPLATTE**

**HM PF**

**SS**

**ATTACCHI FLANGIA SAE  
SAE PORTS  
SAE FLANSCHANSCHLÜSSE**

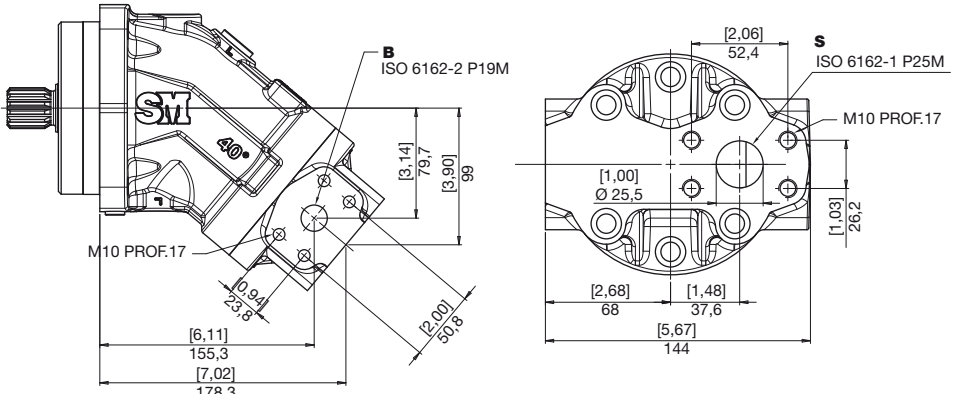

**FS**

**ATTACCHI FILETTATI GAS  
GAS THREADED PORTS  
GEWINDEANSCHLUSSE SEITLICH GAS**

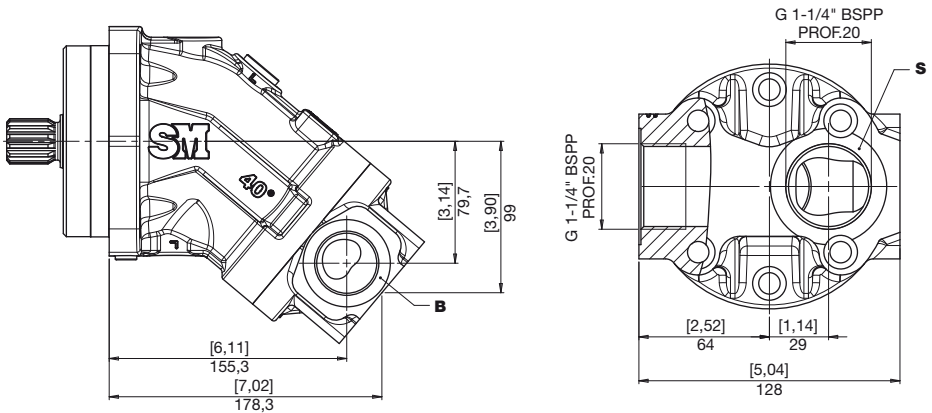

Nella versione sinistra il distributore è ruotato 180°.

In left version the port plate is 180° rotated.

In der linken Version ist der Verteiler um 180° gedreht.

